

Workshop Manual

Compressor Blocks

K100 to K28

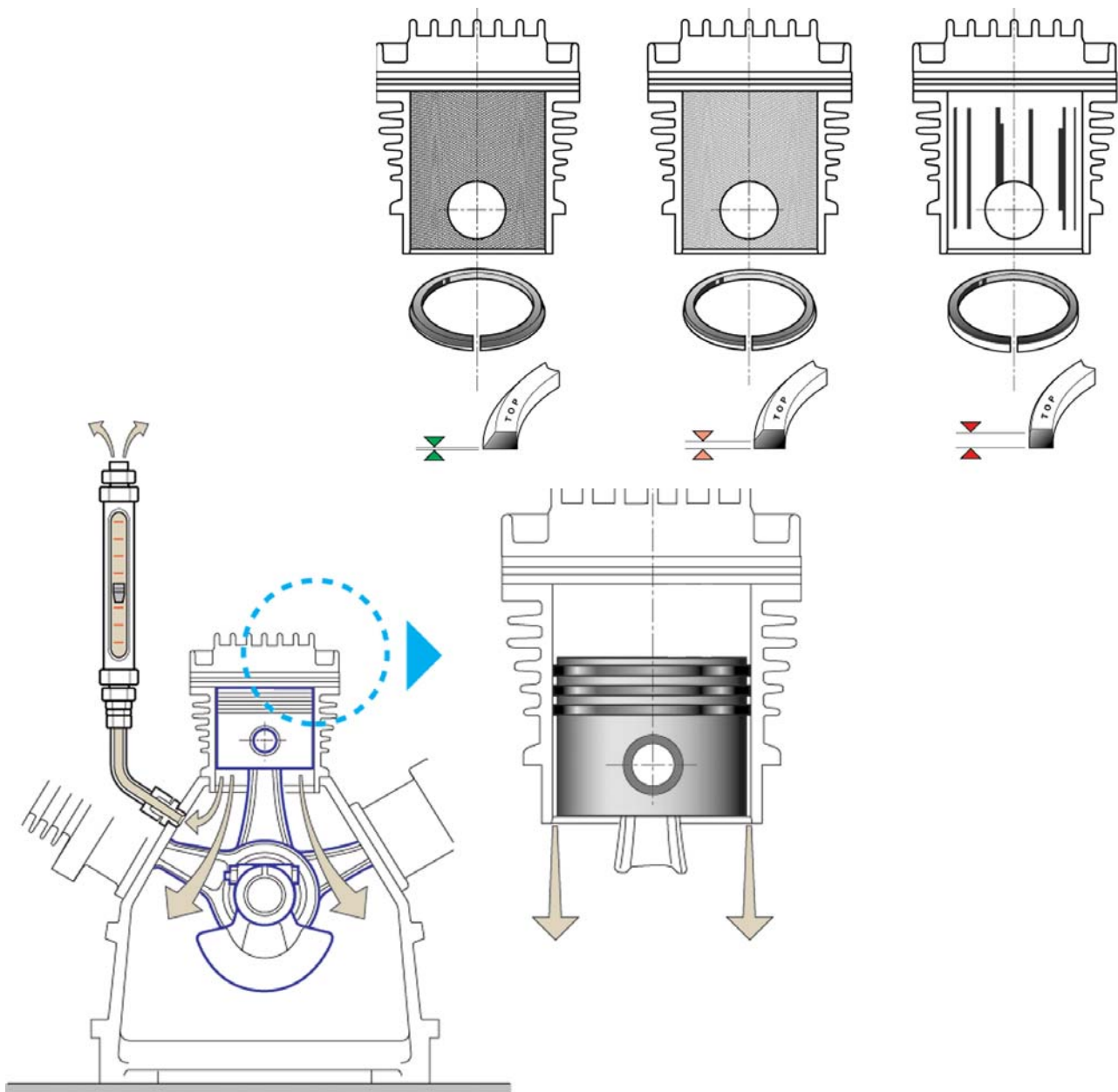

BAUER KOMPRESSOREN GmbH

Postfach 710260 D-81452 München Tel. 089/78049-0 Fax 089/78049167

Workshop Manual

Table of contents

1.	Preface	7
2.	Important Notes	8
2.1.	Safety notes:	8
2.2.	For spare parts orders please observe:	8
2.3.	Please do not pollute the environment:	8
2.4.	Change notice	9
3.	Tables	10
3.1.	Torque values	10
3.2.	TORQUE SEQUENCE	13
3.3.	Tubing and pipe connections	14
3.4.	LUBRICATION CHART	19
3.5.	ADHESIVE AND SEALANT CHART	19
3.6.	TESTING AGENTS	19
3.7.	SPECIAL TOOLS	20
4.	Valves	22
4.1.	Valve maintenance – Wear limits	22
4.2.	Valve maintenance – general notes	23
4.3.	Compressor Blocks IK100 II, IK120 II, BK12.2 II; U/C/M II	24
4.4.	COMPRESSOR BLOCK IK12.14 II	31
4.5.	COMPRESSOR BLOCK IK150 mod. 9, IK180 mod. 4	37
4.6.	COMPRESSOR BLOCK IK18.1	41
4.7.	COMPRESSOR BLOCKS IK150 II mod. 10, IK15.1 II mod. 11, IK15.11 II mod. 1, IK180 II mod. 5, IK18.1 II mod. 4	44
4.8.	COMPRESSOR BLOCK K22	51
4.9.	COMPRESSOR BLOCK K23	58
4.10.	COMPRESSOR BLOCKS K25, K28	66
4.11.	KOMPRESSORBLOCK IK22.2	74
4.12.	COMPRESSOR BLOCK IK22.5	78
4.13.	COMPRESSOR BLOCK IK23.4	80
4.14.	COMPRESSOR BLOCKS IK25.4, IK28.2	84
4.15.	COMPRESSOR BLOCK IK25.5, IK28.3	89
5.	Wear and tear assessment of piston rings, pistons and cylinders	90
5.1.	Procedure	90
5.2.	Blow-By Test	90
5.3.	Blow-By Table	92
6.	Cylinders and Pistons	93
6.1.	General	93
6.2.	Wear characteristics on piston rings:	95

Table of contents

6.3.	Wear characteristics on cylinders:	96
6.4.	Wear characteristics on pistons:	96
6.5.	Piston ring gap test	98
6.6.	Mounting instructions for piston rings	99
7.	Oil quantities	100
8.	Condensate valves	101
9.	Pressure maintaining valves	106

Workshop Manual

Table of figures

Fig. 1	Stepped piston	11
Fig. 2	Taper-Lockt bushing	12
Fig. 3	Torque sequence	13
Fig. 4	Special tools	20
Fig. 5	Valve head 1st stage, IK100	25
Fig. 6	Valve head 1st stage, IK120 II	25
Fig. 7	Valve, 2nd stage	26
Fig. 8	Removing the intake valve	27
Fig. 9	Unscrewing the cap nut	28
Fig. 10	Removing the screw-in pressure plug	28
Fig. 11	Securing the intake valve	29
Fig. 12	Valve head 3rd stage	30
Fig. 13	Removal of 3rd stage pressure valve	30
Fig. 14	Valves 2nd stage	31
Fig. 15	Valves 3rd stage	32
Fig. 16	Removing the intake valve	32
Fig. 17	Unscrewing the cap nut	33
Fig. 18	Removing the screw-in pressure plug	33
Fig. 19	Securing the intake valve	34
Fig. 20	Valve head 4th stage	35
Fig. 21	Removal of 4th stage pressure valve	36
Fig. 23	Valve head and valves, 2nd/3rd stage	38
Fig. 24	Valve head and valves, 4th stage	40
Fig. 25	Valve head and valves, 2nd stage	41
Fig. 26	Valve head 4th/5th stage	42
Fig. 27	Removal of 4th/5th stage pressure valve	43
Fig. 28	Valve head and valves, 1st stage	45
Fig. 29	Valve head and valves, 2nd/3rd stage	46
Fig. 30	Valve head and valves, 2nd stage IK18.1 II	47
Fig. 31	Removing the intake valve	48
Fig. 32	Securing the intake valve	49
Fig. 33	Valve head 4th/5th stage	50
Fig. 34	Removal of 4th/5th stage pressure valve	50
Fig. 35	Valve head and valves, 1st stage	52
Fig. 36	Cylinder, 1st/2nd stage with 2nd stage valves	53
Fig. 37	Valve head and valves, 3rd stage	55
Fig. 38	Valve head and valves, 4th stage	57
Fig. 39	Valve head, 1st stage	58
Fig. 40	Valves, 1st stage	59
Fig. 41	2nd stage valve head	60
Fig. 42	2nd stage valves	61
Fig. 43	Cylinder, 3rd stage and valve head	62
Fig. 44	Valve head and valves, 3rd stage	62
Fig. 45	Cylinder and valve head, 4th stage	63
Fig. 46	Valve head and valves, 4th stage	64
Fig. 47	Valve head and valves, 1st stage	66
Fig. 48	Valve head and valves, 2nd stage	68
Fig. 49	Valve head and valves, 3rd stage	70

Table of figures

Fig. 50	Valve head and valves, 4th stage	72
Fig. 51	Valve head and valves, 1st stage	75
Fig. 52	Valve head and valves, 2nd stage	76
Fig. 53	Valve head and valves, 3rd stage	78
Fig. 54	Cylinder head 2nd/3rd stage with valve head 2nd stage	80
Fig. 55	Cylinder 1st/2nd stage with 2nd stage valves	81
Fig. 56	Valve head and valves, 3rd stage	82
Fig. 57	Valve head 1st stage	84
Fig. 58	Valve head 2nd stage	84
Fig. 59	Valve head and valves, 1st and 2nd stage	85
Fig. 60	Cylinder and valve head 3rd stage	86
Fig. 61	Valve head and valves, 3rd stage	87
Fig. 62	3rd stage valve head	89
Fig. 63	Blowby test	91
Fig. 64	Piston rings in a stepped cylinder	93
Fig. 65	Stepped piston marks	94
Fig. 66	Wear signs of piston rings	95
Fig. 67	Cylinder wear	97
Fig. 68	Checking the piston ring gap	99
Fig. 69	Pressure maintaining valve	109
Fig. 70	Pressure maintaining valve, 350 bar units /3600	110
Fig. 71	Pressure maintaining valve, 500 bar units	111
Fig. 72	Pressure maintaining valve, 90 bar units	112

Workshop Manual

1. Preface

This Workshop Manual has been issued for service and repair shops. It describes all dismantling and assembly procedures required for adjustment and replacement of parts on compressor blocks.

It is presumed that all work is performed by trained specialists. Therefore, all descriptions of basic procedures have been omitted. The procedures contained in this manual refer to the latest state of construction of the compressors at date of issue of this manual.

We would like to emphasize that under no circumstances BAUER Kompressoren GmbH will be held liable for any repair work done by oneself.

For all service and maintenance work please refer to the operating manual applicable for the specific compressor model.

Not contained in this manual are the **BAUER** scuba diving compressors Varius, Purus, Utilus 10, Junior and Oceanus. For those, a separate workshop manual is available.

We reserve the right to make changes to all individual items and accessories according to state of the art requirements in improving performance or as necessitated by safety or commercial restrictions.

Munich,.....January 2003

BAUER-KOMPRESSOREN GmbH
Technical Service Dept.
Technical Documentation Dept.

2. Important Notes

2.1. Safety notes:

- Always shut down and decompress the complete system prior to carrying out any work on the compressor.
- Always disconnect electric units from the power supply prior to carrying out any work on the compressor.
- Never repair pressure lines by soldering or welding.
- Never tighten tube connectors under pressure.

2.2. For spare parts orders please observe:

For all spare parts orders the following data are required:

- Type
- Serial no.
- Year of manufacturing

The required data are found on the compressor identification plate of from the the compressor block number stancelled into the crankcase.

2.3. Please do not pollute the environment:

- The condensate from the filters, and the filter cartridges contain oil and must be disposed of according to local regulations.

Workshop Manual

2.4. Change notice

Change no.	Date of change
0	January 2003; basic edition

Dear customer

We are happy to give you advice on any questions regarding your BAUER compressor and help as soon as possible with any arising problems.

You can contact us Mondays to Thursdays from 08⁰⁰ till 16³⁰, Fridays from 08⁰⁰ till 14⁰⁰ on phone no. (089) 78049-0.

If you call the following extensions directly, it will save you time and repeated dialling.

Do you want to order spare parts?

☞ **Customer service** Phone no: (089) 78049-129 or -149
Fax no: (089) 78049-101

Do you have problems with maintenance or repair work?

☞ **Technical customer service** Phone no: (089) 78049-246 or -176
Fax no: (089) 78049-101

Do you need further information regarding your unit, accessories, prices etc.?

☞ **Sales department** Phone no: (089) 78049-138, -185, -154, -205 or -202
Fax no: (089) 78049-103

Are you interested in any training courses?

☞ **Training manager** Phone no: (089) 78049-175
Fax no: (089) 78049-103

Meet us in the internet at: www.bauer-kompressoren.de

3. Tables

When doing any repair work please check that at all screws and bolts are tightened with the correct torque values.

3.1. Torque values



Unless otherwise specified in text, the following torque values apply. All valve head screws require torque wrench tightening! The indicated torque values are valid for bolts in greased condition. Replace self-retaining nuts on reassembly.

Standard Bolts and screws	Thread	Max. torque
Hex and allen head	M 6	10 Nm (7 ft.lbs)
Hex and allen head	M 8*	25 Nm* (18 ft.lbs)
Hex and allen head	M 10	45 Nm (32 ft.lbs)
Hex and allen head	M 12	75 Nm (53 ft.lbs)
Hex and allen head	M 14	120 Nm (85 ft.lbs)
Hex and allen head	M 16	200 Nm (141 ft.lbs)

Special screws	Thread	Max. torque
Intake valve 07790	M 14x1	30 Nm (21 ft.lbs)
Intake valve fitting 12841	M 28x1,5	60 Nm (42 ft.lbs)
Pressure valve fitting 14124	M 28x1,5	30 Nm (21 ft.lbs)
Studs (pressure valves –small blocks)	M 8x1 M 8x1,25	15 Nm (11 ft.lbs)
Studs (Intake/pressure valves – big blocks)	M 10	35 Nm (25 ft.lbs)
Studs (Intake/pressure valves – big blocks)	M 12	50 Nm (35 ft.lbs)
Studs (Intake/pressure valves – big blocks)	M 14	80 Nm (64 ft.lbs)

* Exception: mounting bolts of final pressure safety valve: 10 Nm

Workshop Manual

Stepped pistons – antifatigue bolts	Thread	Max. torque
K12.14	M 6	10 Nm (7 ft.lbs)
K22.0	M 10	30 Nm (21 ft.lbs)
K23.0, IK23.4	M 10	30 Nm (21 ft.lbs)
K25.0	M 12	35 Nm (25 ft.lbs)
K25.5	M 10	30 Nm (21 ft.lbs)
K28.3	M 10	30 Nm (21 ft.lbs)
K25.9, K25.18	M10	30 Nm (21 ft.lbs)

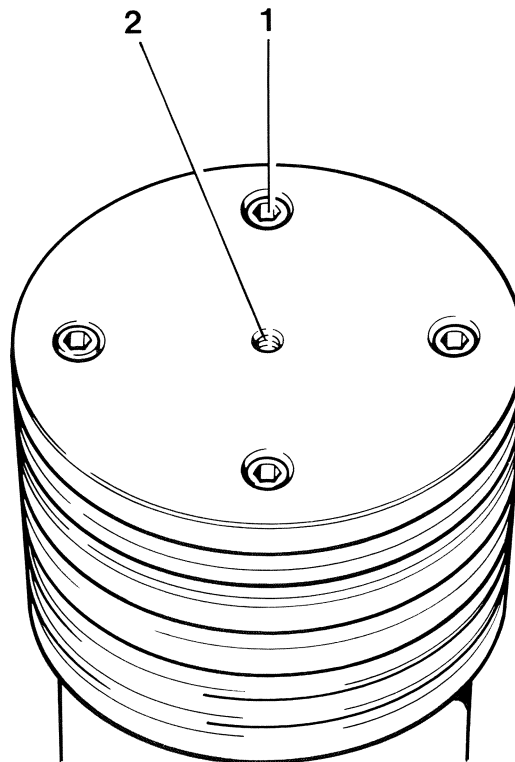

Fig. 1 Stepped piston

- 1 Antifatigue bolt
- 2 Dead thread for pulling the upper piston part

Taper-Lock™ bushing – studs	
Bushing Type/No.	Max. torque
1008, 1108	5 Nm (3,5 ft.lbs)
1210, 1215	20 Nm (14 ft.lbs)
1310, 1315	20 Nm (14 ft.lbs)
1610, 1615	20 Nm (14 ft.lbs)
2012, 2017	30 Nm (21 ft.lbs)
2517, 2525	45 Nm (32 ft.lbs)
3020, 3030	70 Nm (49 ft.lbs)

It is recommended to secure the studs with one drop of a medium screw fastener, e.g. LOCTITE™ 242 / 243.

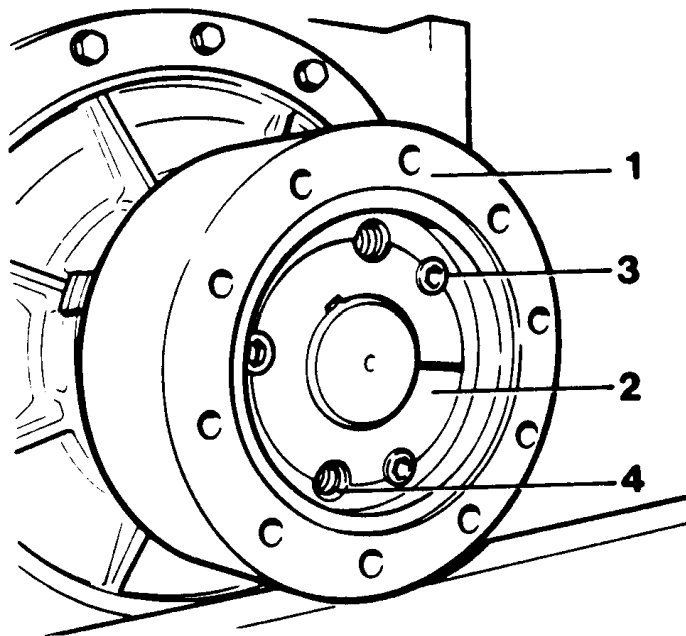

Fig. 2 Taper-Lock™ bushing

- 1 Flywheel
- 2 Taper-Lock™ bushing
- 3 Stud
- 4 Thread for jackscrew

Workshop Manual

3.2. TORQUE SEQUENCE

Tighten valve head and cylinder bolts/nuts equally in the sequence shown in Fig. 3.

Be sure to tighten all parts in **cold to handwarm** condition only.

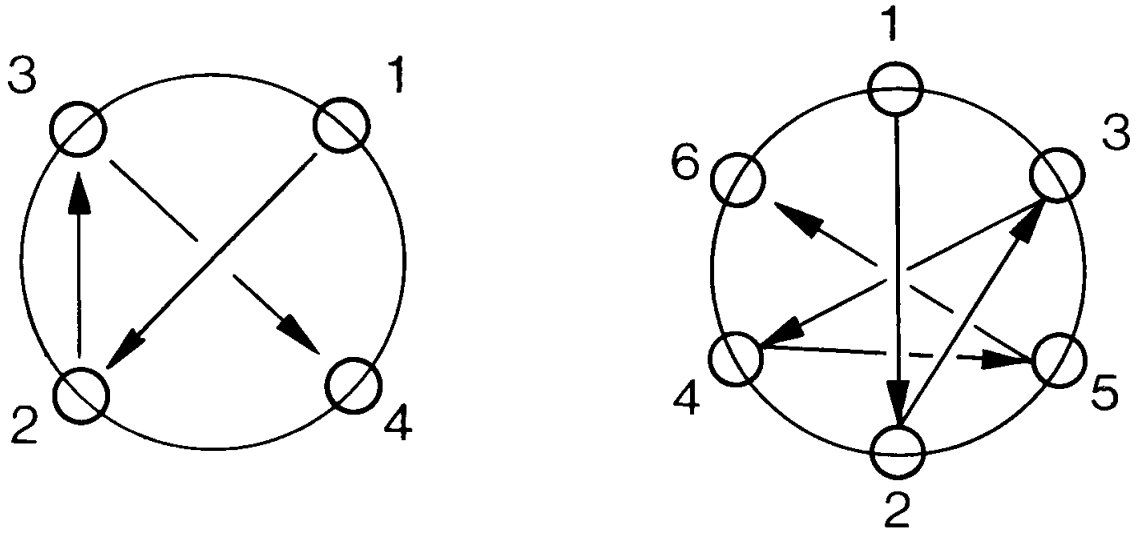
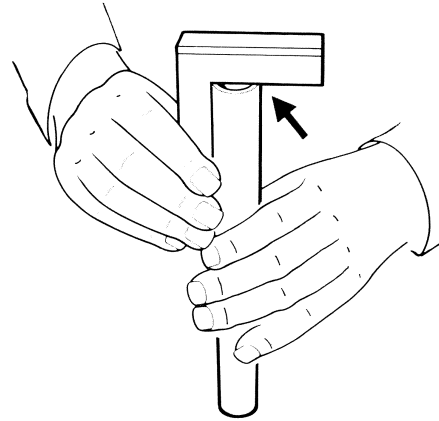

Fig. 3 Torque sequence

3.3. Tubing and pipe connections

Leaks at the fittings will be the most commonly encountered. These may generally be repaired by tightening the joint. It should be emphasized that the compression type coupling fittings are capable of exerting extreme forces on the tubing and should not be tightened more than is required to seal the joint. To improve the sealing of the pipe connections and to facilitate the installation the following should be observed:

Ensure the pipe to be cut at right angles



The pipe should preferably be cut in a pipe cutting jig.

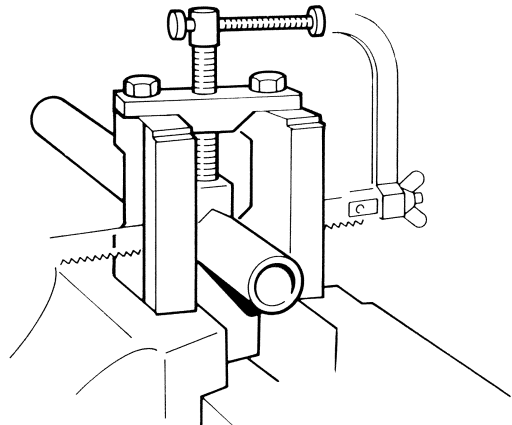

Debur the inside and outside edge of the tube after cutting and clean the inside of the tube to remove even the slightest trace of cuttings.

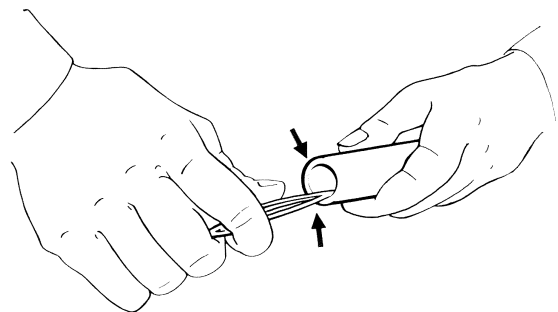

Workshop Manual

Apply a thin layer of lubricant to the thread (e.g. N19753).

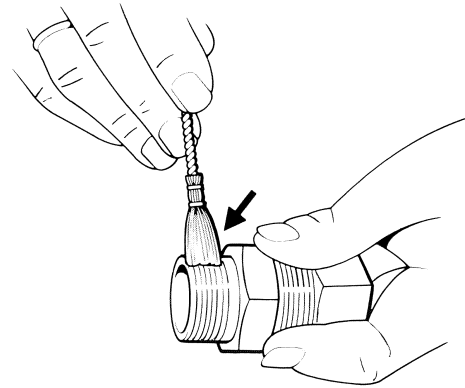

Smear a thin layer of lubricant onto the outside of the olive on assembly (e.g. N19753).

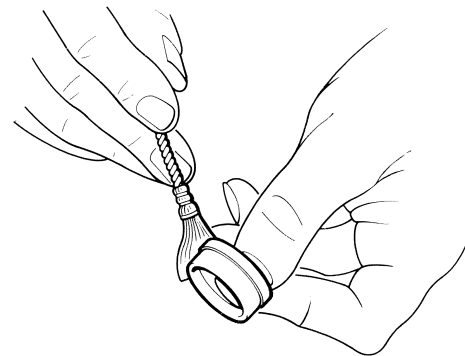

Apply a thin layer of lubricant to the thread of the nut (e.g. N19753).

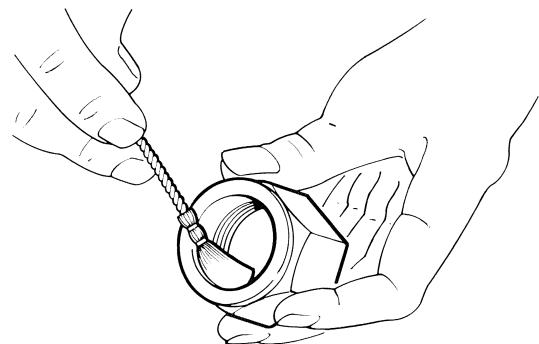

Install nut and olive as shown

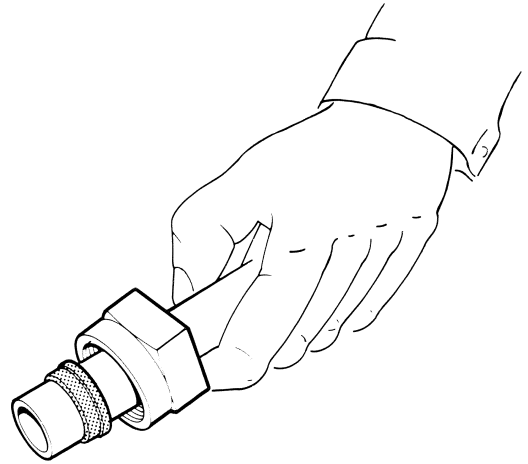

Do not fit the olive the wrong way as it will not seal.

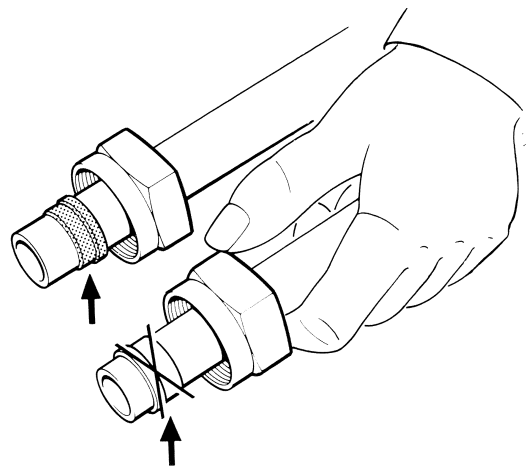

Fingertighten the nut.

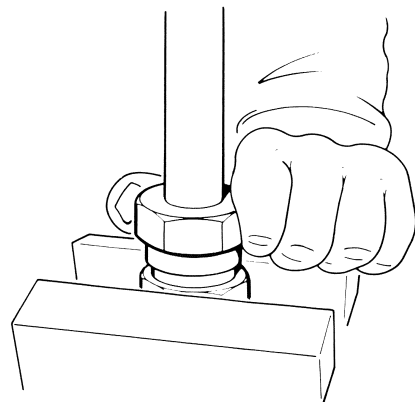

Workshop Manual

Push the pipe down into the connector until it bottoms.

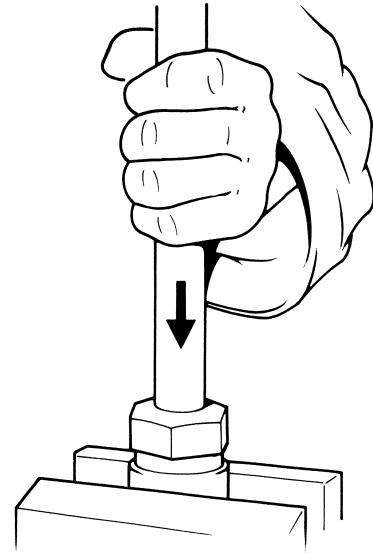

Mark the nut and the pipe to determine the number of turns the nut has been tightened.

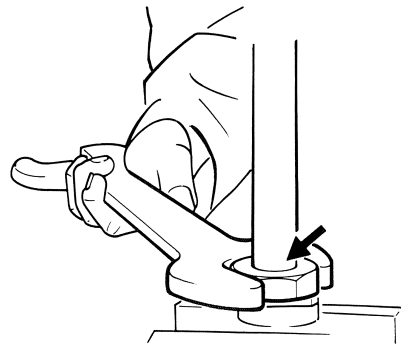

Tighten the nut another 1 – 1^{1/4} turns ensuring the pipe does not rotate. The olive grips onto the pipe.

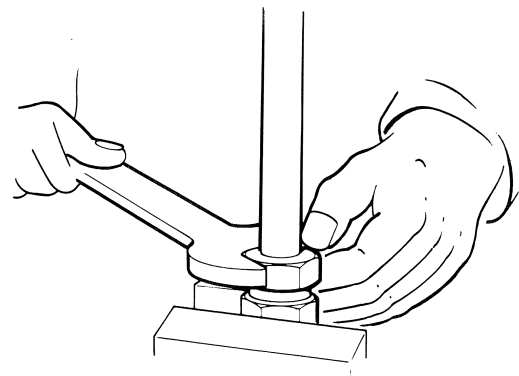

Unscrew the nut and check if the collar is well formed. If not, the nut should be tightened slightly more. The olive can, however be free to rotate without negative effects on the sealing ability.

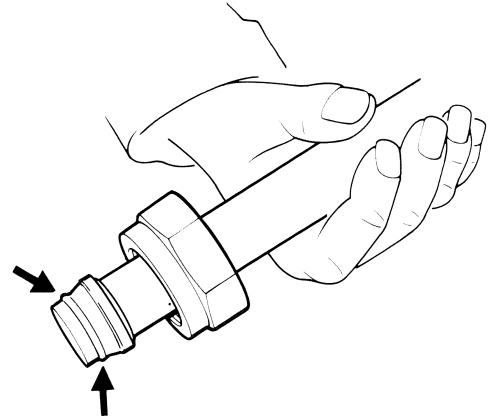

At final installation the nut should only be tightened to a position ensuring the connection to be tight, i.e. finger-tight + approx. 1/2 turn. After this assembly procedure the nut, olive, tube and connector should be considered to be a matched assembly and must not be interchanged with similar parts.

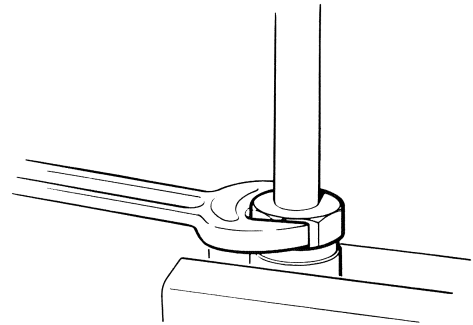

Workshop Manual

3.4. LUBRICATION CHART

Usage	Lubricants
Rubber and plastic parts, filter housing threads	WEICON WP 300 WHITE part no. N19752 or BAUER special lubricant P/N 072500
Sealing rings	BAUER special lubricant P/N 072500
Shaft seal (seal) Shaft seal (shaft)	BAUER special lubricant P/N 072500 Klüber SK 01-205
Screws, bolts, threads	WEICON ANTI-SEIZE AS 040 P part no. N19753 or equivalent compound with copper or MoS ₂ additives

For all lubricating oils refer to chapter 2 or lubricating oil list available through **BAUER** Service Department.

3.5. ADHESIVE AND SEALANT CHART

Usage	Adhesives and Sealants
Screws, Studs	Loctite 2701
Seal for conical threads	Loctite 243
Metal – metal seals High temperature connections, e.g. valve heads, cylinders	Temperature resistant compound, e.g. WACKER E10, part no. N18247
Paper gaskets	Loctite FAG 2

3.6. TESTING AGENTS

Usage	Testing agents
Tube connectors, tubes	Leakage test spray, part no. FM0089

3.7. SPECIAL TOOLS

The parts no. are listed in the table on the next page.

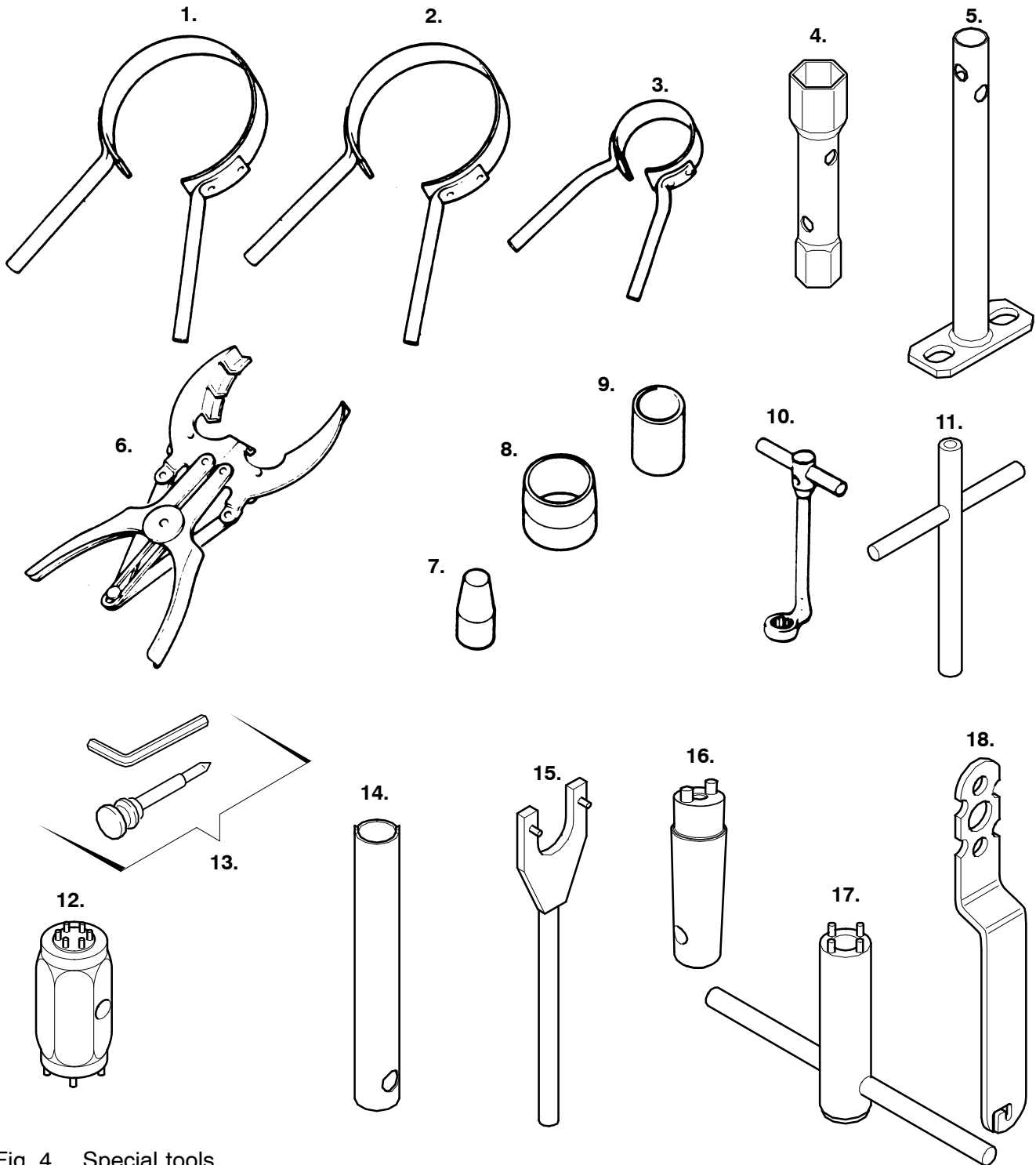

Fig. 4 Special tools

Workshop Manual

Items printed in bold letters are shown in Fig. 4.

Pos.	Designation	Part no.
1.	Piston ring band Ø 130	65901
	Piston ring band Ø 160	65039
2.	Piston ring band Ø 88, small	67976
	Piston ring band Ø 88, large	57494
3.	Piston ring band Ø 45	57498
	Piston ring band Ø 36	57499
	Piston ring sleeve Ø 22	57406
4.	Filter key, Seccant	N29373
5.	Filter key, Seccant	66690
6.	Piston ring pliers 110–160mm	N16721
	Piston ring pliers 126/1–100	N4452
	Piston ring pliers 126/2–120	N4453
7.	douille de montage Ø 22	57393
8.	douille de montage Ø 45	57643
9.	douille de montage Ø 18	64823
10.	Key, cylinder base	N3408
11.	Key, for extraction of jumbo-cartridge	067146
12.	Key, for valve head	82048
13.	tool set for drain tap	067458
14.	Key, insert of intermediate filter	79846
15.	Key for safety valve	57478
16.	Key for pressure maintaining valve	81193
17.	Key for pressure maintaining valve	85154
18.	Filter key, P-Filter system	60074
19.	Test pressure gauge, 0–16 bar	057491
20.	Test pressure gauge, 0–100 bar	057492
21.	Flowmeter 0 – 50 l/min.	81187-KD
22.	Flowmeter 0 – 100 l/min.	81218-KD

4. Valves

4.1. Valve maintenance – Wear limits

Wear limits for intake and pressure valves:

Wear of intake and pressure valves of air and gas compressors depends on different parameters, e.g.:

- Operating pressure,
- Ambient temperature,
- Operating temperature,
- Lube oil,
- Carbonization
- Condensate build-up
- Intake filter

etc.

Workshop Manual

4.2. Valve maintenance – general notes

- **Always replace** valves as a complete set.
- **Carefully clean** dirty valves. Never use a sharp tool for this purpose. Soak the valves in diesel oil or petroleum and clean with soft brush. Preferably use an ultrasonic cleaner, if possible.
- Use **maintenance kits**^{a)}
- **Lubricate** the copper gasket area of the valves before installing with high temperature compound, part no. N19753, or equivalent.
- **Observe** the correct sequence when fitting together again.
- **Check** individual components for excessive wear. If the valve seat and valve disks are dented, replace the valves.
- **Valve head screws** must be tightened with a torque wrench (see tightening torque values chapter 3.).
- **Check** the valve space in the valve heads for dirt and clean, if necessary, preferably in an ultrasonic cleaner.
- **Use only** satisfactory gaskets and O-rings on reassembly.
- **After finishing** all maintenance work on the valves, turn the compressor manually using the flywheel and check whether all items have been correctly installed.
- **30 minutes after restarting** the compressor unit stop unit, let it cool down to ambient temperature and retighten valve studs and cap nuts. Otherwise valves could work loose due to setting of the gaskets.
- **After 3 operating hours** retighten all pressure bolts and valve caps of pressure valves with the correct torque values (refer to special torque value table) to avoid valves working loose due to setting of the gaskets.
- A **functional inspection of the valves** can be done by checking the intermediate pressures.
- **Remove and check** the valves every **1000 operating hours**. (CNG plants 2000 h).
- **Replace** the valves every **2000 operating hours** to avoid fatigue failure. (CNG plants 4000 h).

a) erhältlich über BAUER-Kundendienst.

4.3. Compressor Blocks IK100 II, IK120 II, BK12.2 II; U/C/M II

4.3.1. Changing the valves of the 1st stage, IK100II

Removal

- Remove pressure line.
- Remove cap nut (1, Fig. 5) and gasket.
- Remove stud (2).
- Remove plug (3) and take out spring washer, o–ring and pressure valve parts (4).
- Remove allen screws (5), and take off valve head (6).
- Remove o–Ring and intake valve plate (7).
- Clean intake and pressure valve (preferably ultra sound bath) and check for damage. Valve seats and plate valves must not show any signs of wear or damage. Replace damaged parts.
- Replace damaged parts.
- Clean cylinder head. Check that the intake and pressure valve bores are in perfect condition.
- Check with a precision straightedge that the underside of the cylinder head is flat, if necessary use an emery cloth to smooth out the surface.

Reassembly

- Replace pressure valve parts (4). Check for correct sequence.
- Screw in plug (3) with spring washer and tighten (refer to torque table).
- Grease stud (2) slightly (e.g. N19753), tighten (refer to torque table), mount a new gasket and counter with cap nut (1) (refer to torque table).
- Mount new o–ring and intake valve plate (7).
- Place cylinder head on cylinder, slightly grease allen screw (5) crew in and tighten with correct torque value (refer to torque table)
- Replace pressure line.

Workshop Manual

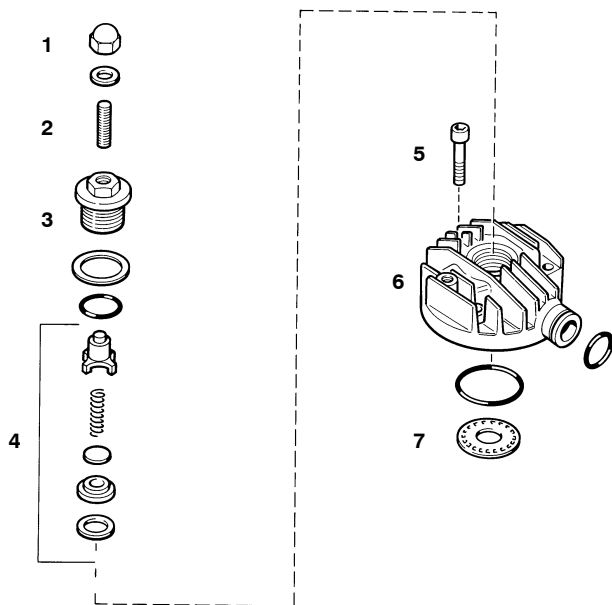
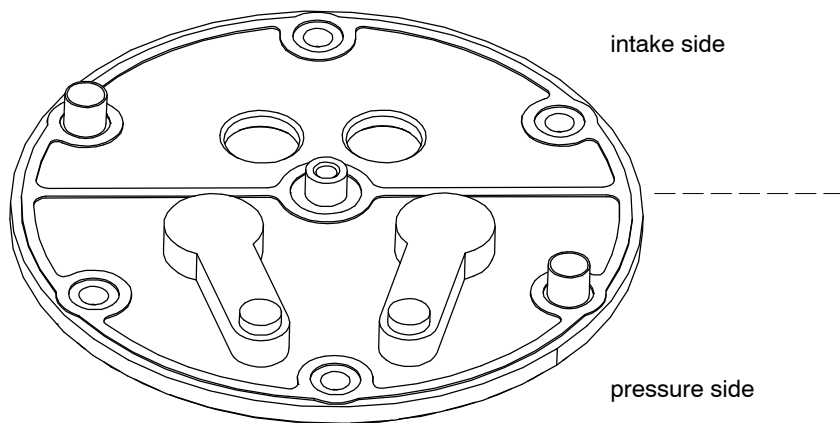

Fig. 5 Valve head 1st stage, IK100

4.3.2. Changing the valves of the 1st stage, IK120II

Intake and pressure valve of the 1st stage are combined in one plate valve under the valve head. Check that the valve is fitted as shown in Fig. 6.



Top view

Fig. 6 Valve head 1st stage, IK120 II

4.3.3. Changing the valves of the 2nd stage, (1st stage BK12.2II)

- Unscrew the intake and pressure lines from the cylinder head (7, Fig. 7).

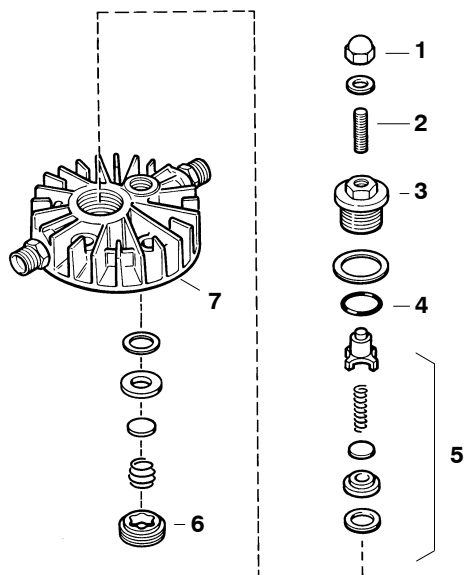

Fig. 7 Valve, 2nd stage

- Remove allen screws fixing cylinder head and completely remove the cylinder head from the cylinder.
- Insert two metal pins – 8 mm diameter , any length – in the holes in the cylinder head and secure these in a vice with the cylinder head on top.
- Unscrew the intake valve body with the special tool (part no. 4555–645, part of the tools set delivered with the unit (Fig. 8).



In order to avoid damaging the special tool or the valve when using the tool, ensure that it is pushed properly and firmly into the valve bore so that it will not tilt when it is turned.

- Turn the cylinder head and replace it on the metal pins.
- Unscrew the cap nut (1) (see Fig. 9).
- Unscrew stud (2) approx. 5 turns.
- Unscrew screw-in pressure plug (3), see Fig. 10. Take out the pressure valve parts.
- Clean intake and pressure valves and check for damage. Valve seats and plate valves must not show any signs of wear or damage. Replace damaged parts.
- Check O-ring (4), replace if necessary.
- Clean cylinder head. Check that the intake and pressure valve bores are in perfect condition.
- Check with a precision straightedge that the underside of the cylinder head is flat, if necessary use an emery cloth to smooth out the surface.

Workshop Manual

Assembly:

- Screw the intake valve in with the special tool and tighten.



Valve spring and valve plate must not be jammed.

- Check valve function. To do so, blow compressed air through the valve in the direction of flow.
- Secure the intake valve as follows:
Peen the cylinder head aluminium on the screw-in thread of the intake valve in two places opposite one another with a small drift pin, diameter approx. 5 mm (Fig. 19).
- Insert the pressure valve parts and the O-ring.



Check the pressure valve function and stroke by lifting the valve plate.

- Screw in the screw-in pressure plug with a pressure pad and tighten.



Ensure that the stud is unscrewed.

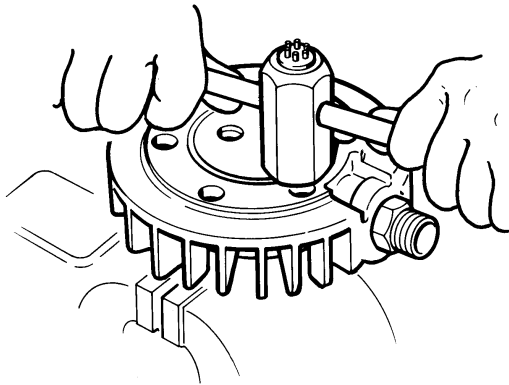

Fig. 8 Removing the intake valve

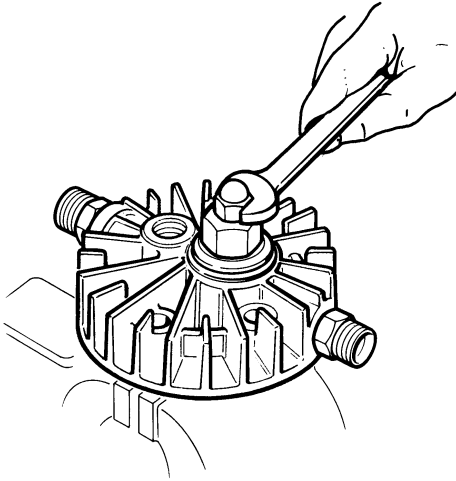

Fig. 9 Unscrewing the cap nut

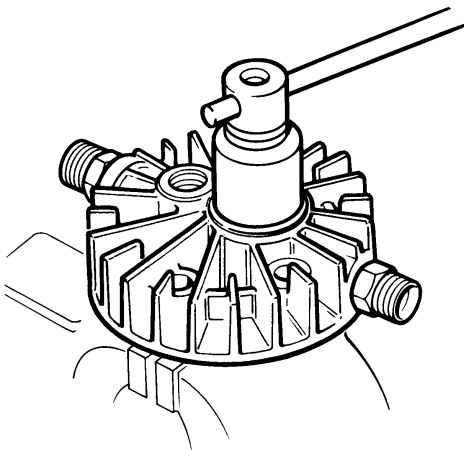

Fig. 10 Removing the screw-in pressure plug

- Screw in the stud firmly, fit a new gasket and secure with the cap nut.
- Put the cylinder head on the cylinder and secure it with the internal hex. screws.
- Reconnect the intake and pressure lines.

Workshop Manual

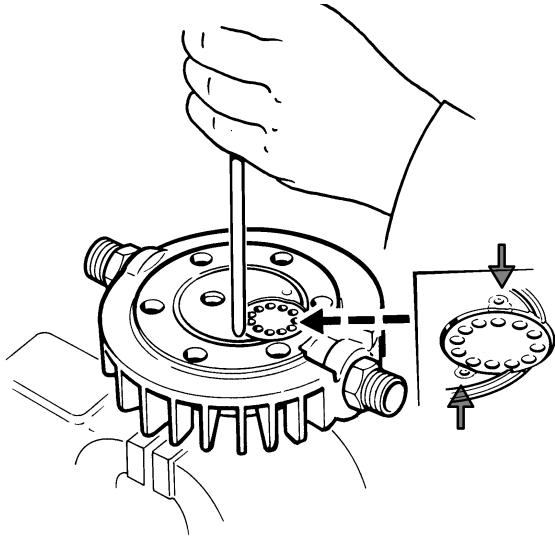

Fig. 11 Securing the intake valve

4.3.4. Changing the valves of the 3rd stage (2nd stage BK12.2II)

For removal and installation of the 3rd stage intake valve proceed according to 4.4.2. Pressure valve (5) is merely inserted into valve head (7). It is sealed by O-ring (4) and fixed to the valve head by stud (3).



Change intake and pressure valves of 3rd stage together, only.

Removal and reinstallation of 3rd stage pressure valve (Fig. 12).

- Remove acorn nut (1), rewind stud (3) up to three or four turns.
- Remove internal hex. screw (9) fixing valve head (7), take off valve head cover (8).
- Put two screwdrivers into the groove of outlet valve body, see Fig. 13. If necessary loosen valve first by using a 13 mm spanner on the flat surfaces.
- Lift out pressure valve (5) together with O-ring (4).

Reinstall pressure valve (5) in reverse sequence:

- Put O-ring (4) into valve head (7). Check O-ring for abrasions.
- Insert pressure valve (5). Put on valve head cover (8).
- Fix valve head (7) with internal hex. screws. Torque to correct value, see chapter 20.
- Screw in and fasten stud (3).
- Put on gasket (2).
- Screw on acorn nut (1).

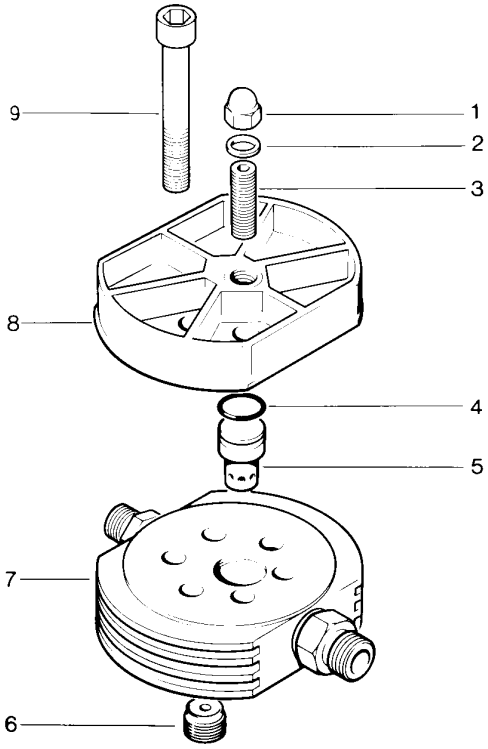

Fig. 12 Valve head 3rd stage

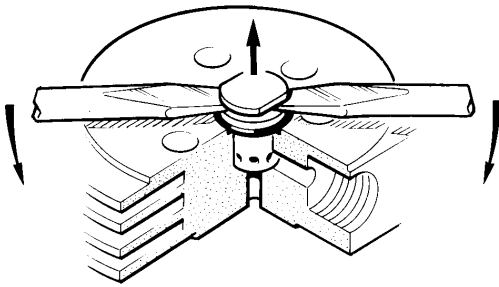

Fig. 13 Removal of 3rd stage pressure valve

Workshop Manual

4.4. COMPRESSOR BLOCK IK12.14 II

4.4.1. Changing the valves of the 1st stage

Intake and pressure valve of the 1st stage are combined in one plate valve under the valve head. When installing, check that the mark "TOP" is really at the top. The stamped "S" indicates the intake side.

4.4.2. Changing the valves of the 2nd stage

- Unscrew the intake and pressure lines from the intake and outlet manifolds (2, Fig. 14).
- Unscrew 4 allen screws ea. (1) and remove intake and outlet manifolds from cylinder.
- Discard gaskets (3) and replace by new ones.
- Clean intake and pressure valves (4) and check for wear and damage.
- Assembly is performed in the reverse sequence of removal.

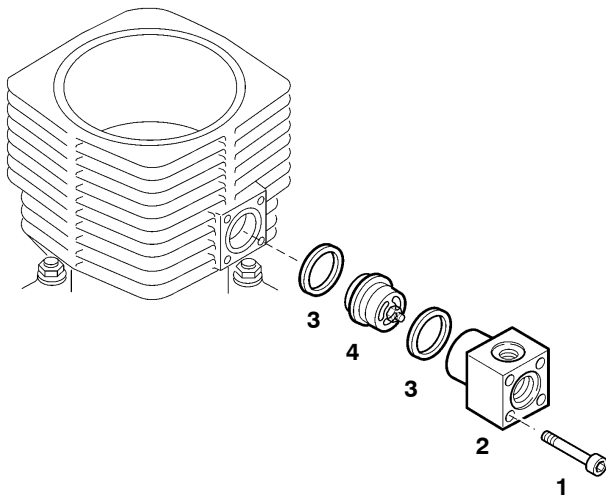

Fig. 14 Valves 2nd stage

4.4.3. Changing the valves of the 3rd stage

- Unscrew the intake and pressure lines from the cylinder head (7, Fig. 15).
- Remove internal hex. screws fixing cylinder head and completely remove the cylinder head from the cylinder.
- Insert two metal pins – 8 mm diameter, any length – in the holes in the cylinder head and secure these in a vice with the cylinder head on top.
- Unscrew the intake valve body with the special tool (part no. 4555–645, part of the tools set delivered with the unit) (Fig. 16).



In order to avoid damaging the special tool or the valve when using the tool, ensure that it is pushed properly and firmly into the valve bore so that it will not tilt when it is turned.

- Turn the cylinder head and replace it on the metal pins.
- Unscrew the cap nut (1, Fig. 15) refer to Fig. 17.

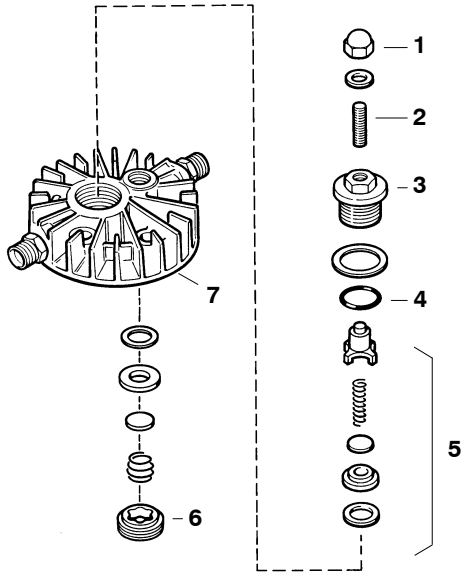

Fig. 15 Valves 3rd stage

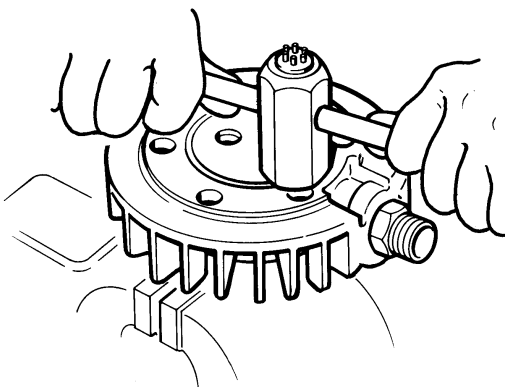

Fig. 16 Removing the intake valve

Workshop Manual

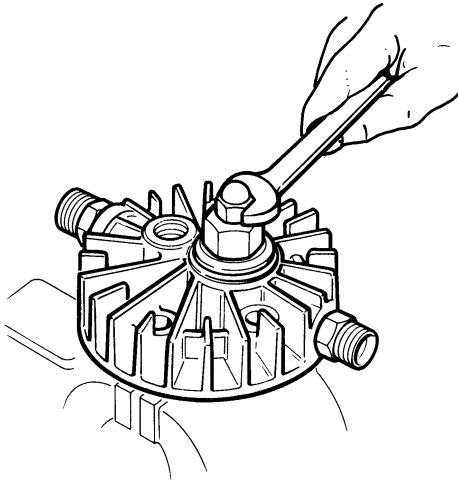

Fig. 17 Unscrewing the cap nut

- Unscrew stud (2) approx. 5 turns.
- Unscrew screw-in pressure plug (3), refer to Fig. 18. Take out the pressure valve parts.
- Clean intake and pressure valves and check for damage. Valve seats and plate valves must not show any signs of wear or damage. Replace damaged parts.

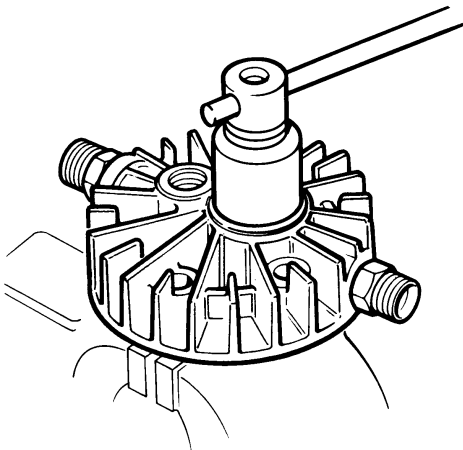

Fig. 18 Removing the screw-in pressure plug

- Check O-ring (4), replace if necessary.
- Clean cylinder head. Check that the intake and pressure valve bores are in perfect condition.
- Check with a precision straightedge that the underside of the cylinder head is flat, if necessary use an emery cloth to smooth out the surface.

Assembly:

- Screw the intake valve in with the special tool and tighten.



Valve spring and valve plate must not be jammed.

Check valve function. To do so, blow compressed air through the valve in the direction of flow.

- Secure the intake valve as follows: Peen the cylinder head aluminium on the screw-in thread of the intake valve in two places opposite one another with a small drift pin, diameter approx. 5 mm (Fig. 19).
- Insert the pressure valve parts and the O-ring.



Check the pressure valve function and stroke by lifting the valve plate.

- Screw in the screw-in pressure plug with a pressure pad and tighten.



Ensure that the stud is unscrewed.

- Screw in the stud firmly, fit a new gasket and secure with the cap nut.
- Put the cylinder head on the cylinder and secure it with the internal hex. screws, for the correct torque value.
- Reconnect the intake and pressure lines.

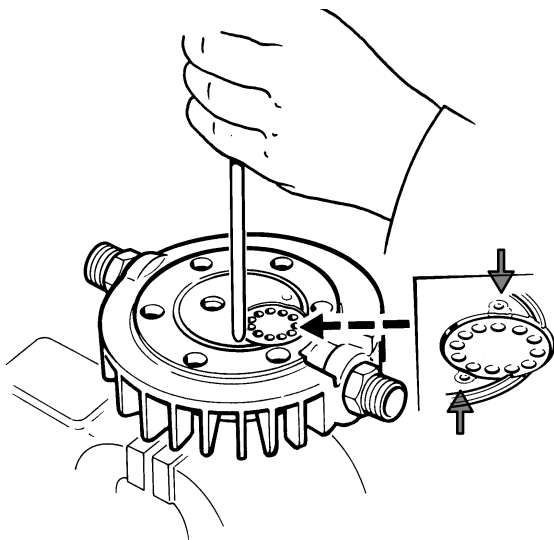

Fig. 19 Securing the intake valve

Workshop Manual

4.4.4. Changing the valves of the 4th stage

For removal and installation of the 3rd stage intake valve proceed according to 4.4.2. Pressure valve (5) is merely inserted into valve head (7). It is sealed by O-ring (4) and fixed to the valve head by stud (3).



Change intake and pressure valves of 4th stage together, only.

Removal and reinstallation of 3rd stage pressure valve (Fig. 20).

- Remove acorn nut (1), rewind stud (3) up to three or four turns.
- Remove internal hex. screw (9) fixing valve head (7), take off valve head cover (8).
- Put two screwdrivers into the groove of outlet valve body, see Fig. 21. If necessary loosen valve first by using a 13 mm spanner on the flat surfaces.
- Lift out pressure valve (5) together with O-ring (4).

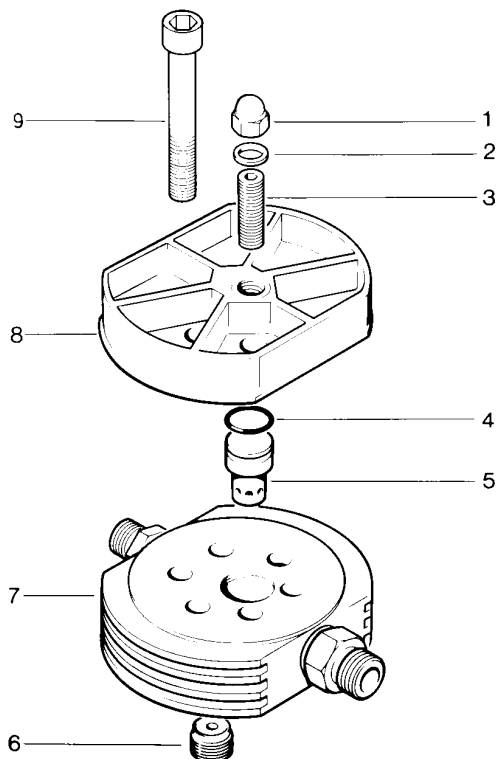

Fig. 20 Valve head 4th stage

Reinstall pressure valve (5) in reverse sequence:

- Put O-ring (4) into valve head (7). Check O-ring for abrasions.

- Insert pressure valve (5). Put on valve head cover (8).

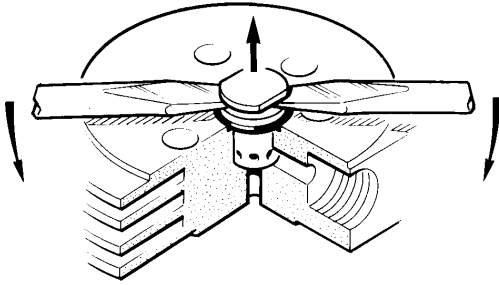

Fig. 21 Removal of 4th stage pressure valve

- Fix valve head (7) with internal hex. screws.
- Screw in and fasten stud (3).
- Put on gasket (2).
- Screw on acorn nut (1).

Workshop Manual

4.5. COMPRESSOR BLOCK IK150 mod. 9, IK180 mod. 4

4.5.1. Changing the valves of the 1st stage

Remove and reinstall the valves for replacement as follows (see Fig. 22).

Removal procedure

- Unscrew and remove cap nut (1).
- Unscrew stud (3) a number of turns.
- Check, and if required, replace gasket (2).
- Remove valve cover nuts (11) and take off valve cover (4).
- Check O-ring (10) and replace if required.
- Take off valve cap (5) and remove the valve (6) or (8).
- Check gasket (7), replace if necessary.

Installation procedure

- Fit new valve with gasket (7) and position valve cap (5).
- Fit valve cover (4) with O-ring (10) and fasten with self-retaining nuts (11).
- Tighten stud (3) using allen key and screw on cap nut (1).

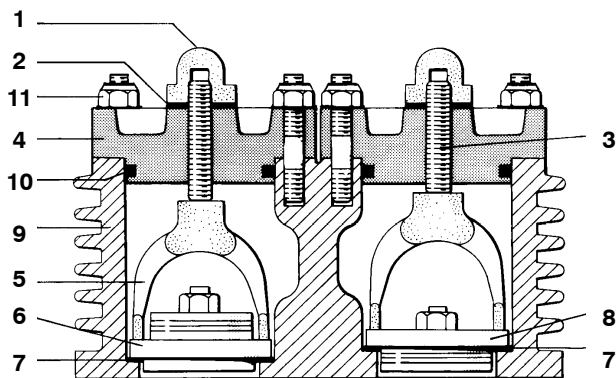

Fig. 22 Valve head and valves, 1st stage

- 1 Cap nut
- 2 Gasket
- 3 Stud
- 4 Valve cover
- 5 Valve cap
- 6 Discharge valve
- 7 Valve gasket
- 8 Inlet valve
- 9 Valve head
- 10 O-ring
- 11 Valve cover nut

4.5.2. Changing the valves of the 2nd and 3rd stages

Remove and reinstall the valves for replacement as follows (see Fig. 23).

Removal procedure

- Unscrew and remove hex. nut (1). Remove cap holder (2).
- Insert two screwdrivers into the groove of the valve cap (3) and lift off valve cap with O-ring (4).
- Check, and if required, replace O-ring (4).
- Take out valves (5) and (6).
- Check valve gasket (7) and replace if required.

Installation procedure

- Fit new valve with gasket (7) and position valve cap (3) with O-ring (4).
- Fit cap holder (2).



The valve cap for the the inlet valve protrudes 2.5 mm (.98 in.) out of the valve head more than the valve cap for the discharge valve. (Cap holder is designed accordingly).

- Screw on hex. nut (1) and tighten with torque wrench.

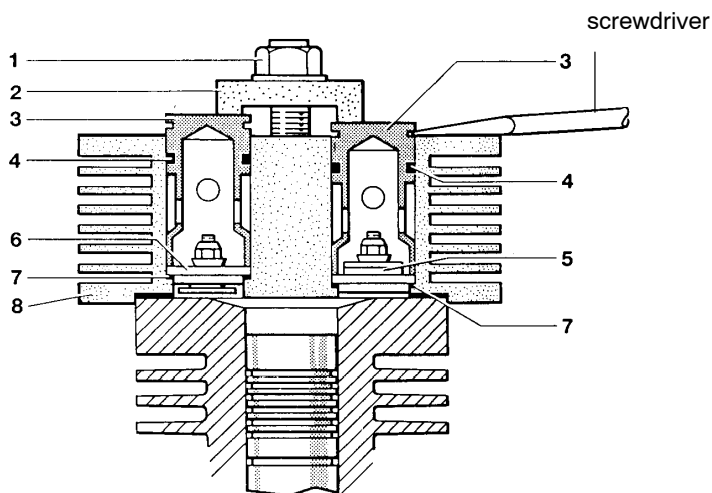

Fig. 23 Valve head and valves, 2nd/3rd stage

- 1 Hex. nut
- 2 Cap holder
- 3 Valve cap
- 4 O-ring
- 5 Discharge valve
- 6 Inlet valve
- 7 Valve gasket
- 8 Valve head

Workshop Manual

4.5.3. Changing the valves of the 4th stage

The valves are located in the valve head of the 4th stage, see Fig. 24. The inlet valve merely comprises a valve disk (6) and a wavy washer (5). The inlet valve seat is machined directly into the cylinder liner (8) of the 4th stage piston. The discharge valve consists of the valve seat (11), valve disk (12), valve spring (13), and stroke limiter (2).

The procedure for removal and reinstallation of the valves is as follows (refer to Fig. 24).

The valve head comprises the bottom section (7) and the upper section (3). The valve head is secured by means of the valve head screw (14) connecting the cylinder.

Removal procedure

- Loosen the inlet and discharge pipe on the valve head.
- Loosen and remove valve head screw (14).
- Take off valve top section (3) and stroke limiter (2) with O-ring (1). This releases the discharge valve disk (12) and discharge valve spring (13).
- Check spring for satisfactory condition and resiliency preferably by comparing with a new spring.
- Replace spring if necessary.
- Check O-ring (1) and replace if necessary.
- Insert two screwdrivers into the extraction groove of the discharge valve seat (11) and lift valve seat with O-ring (9).
- Check, and if required, replace O-ring (9) and backing ring (10).
- Remove wavy washer (5) and inlet valve disk (6).
- Check inlet valve seat on piston liner (8). If scored, remove piston liner, take out piston, and lap valve seat.

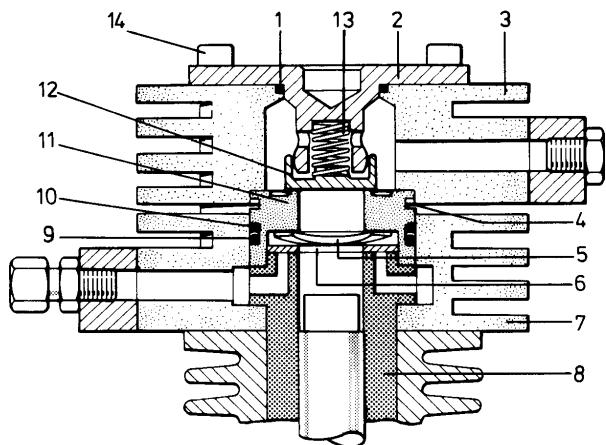

Fig. 24 Valve head and valves, 4th stage

- 1 O-ring
- 2 Stroke limiter
- 3 Valve head, top section
- 4 Extraction groove
- 5 Wavy washer
- 6 Inlet valve disk
- 7 Valve head, bottom section
- 8 Piston liner
- 9 O-ring
- 10 Backing ring
- 11 Discharge valve seat
- 12 Discharge valve disk
- 13 Discharge valve spring
- 14 Valve head screw

Installation procedure

- Turn flywheel on compressor manually until piston protrudes from the cylinder liner (8).
- Locate the inlet valve disk (6) and the wavy washer (5), both of which are prevented from side slip by the piston.
- Insert the discharge valve seat (11) in the bottom section of the valve head (7), taking care to avoid damage to the inlet valve disk and wavy washer.
- Place discharge valve spring (13) and discharge valve disk (12) on stroke limiter (2) and locate this in the top section of the valve head.
- Screw in valve head screws (14) and tighten down diagonally using a torque wrench.
- Tighten inlet and discharge pipe couplings.

Workshop Manual

4.6. COMPRESSOR BLOCK IK18.1

4.6.1. Changing the valves of the 1st stage

See 4.5.1., IK150/180.

4.6.2. Changing the valves of the 2nd stage

Remove and reinstall the valves for replacement as follows (see Fig. 25).

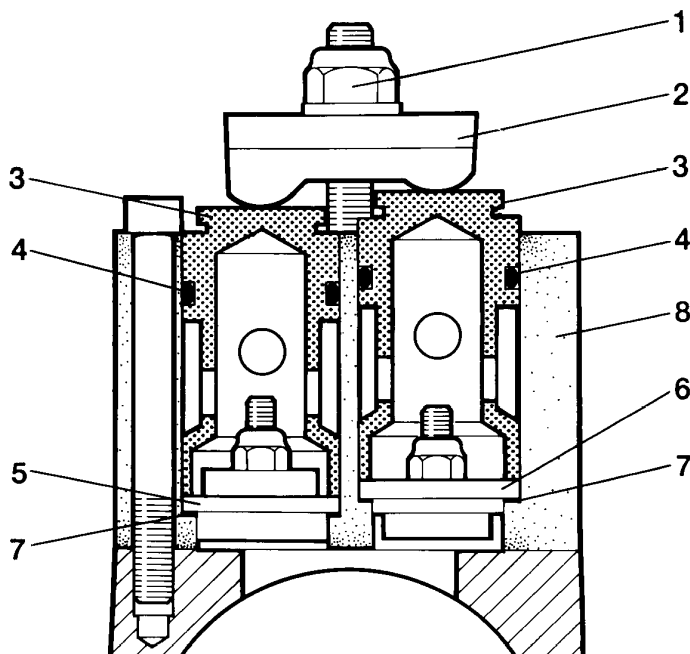

Fig. 25 Valve head and valves, 2nd stage

- 1 Hex. nut
- 2 Cap holder
- 3 Valve cap
- 4 O-ring
- 5 Discharge valve
- 6 Inlet valve
- 7 Valve gasket
- 8 Valve head

Removal procedure

- Unscrew and remove hex. nut (1). Remove cap holder (2).
- Insert two screwdrivers into the groove of the valve cap (3) and lift off valve cap with O-ring (4).
- Check, and if required, replace O-ring (4).
- Take out valves (5) and (6).
- Check valve gasket (7) and replace if required.

Installation procedure

- Fit new valve with gasket (7) and position valve cap (3) with O-ring (4).
- Fit cap holder (2).



The valve cap for the the inlet valve protrudes 2.5 mm (.98 in.) out of the valve head more than the valve cap for the discharge valve. (Cap holder is designed accordingly).

- Screw on hex. nut (1) and tighten with torque wrench.

4.6.3. Changing the valves of the 3rd stage

See 4.5.2., IK150/180.

4.6.4. Changing the valves of the 4th and 5th stage



Change intake and pressure valves together, only.

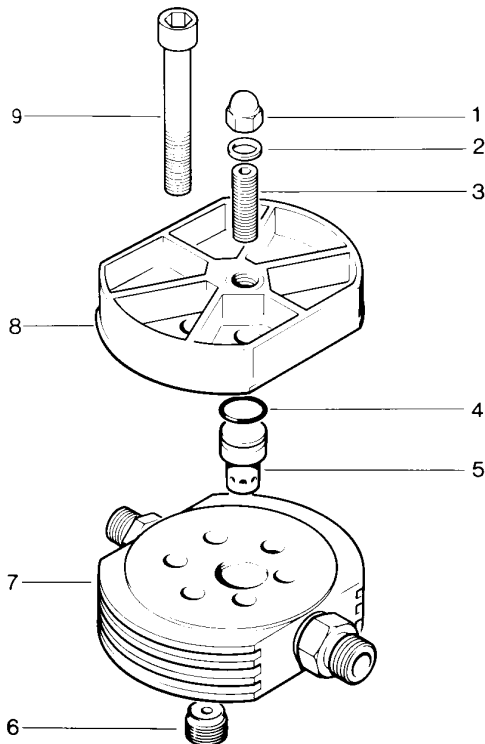

Fig. 26 Valve head 4th/5th stage

- Remove acorn nut (1), rewind stud (3) up to three or four turns.

Workshop Manual

- Remove internal hex. screw (9) fixing valve head (7), take off valve head cover (8).
- Insert two metal pins – 8 mm diameter , any length – in the holes in the cylinder head and secure these in a vice with the cylinder head on top.
- Unscrew the intake valve body (6) with the special tool (part no. 4555–645, part of the tools set delivered with the unit).



In order to avoid damaging the special tool or the valve when using the tool, ensure that it is pushed properly and firmly into the valve bore so that it will not tilt when it is turned.

Pressure valve (5, Fig. 26) is merely inserted into valve head (7). It is sealed by O–ring (4) and fixed to the valve head by stud (3).

Remove pressure valve according to Fig. 27 as follows:

- Put two screwdrivers into the groove of outlet valve body. If necessary loosen valve first by using a 13 mm spanner on the flat surfaces.

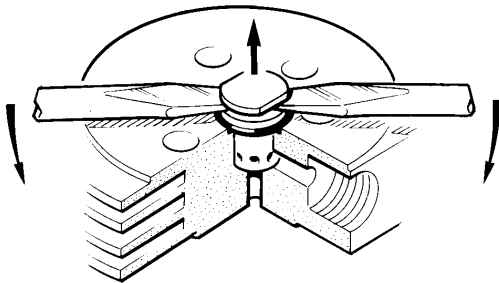

Fig. 27 Removal of 4th/5th stage pressure valve

Reinstall pressure valve (5) in reverse sequence:

- Put O–ring (4) into valve head (7). Check O–ring for abrasions.
- Insert pressure valve (5). Put on valve head cover (8).
- Fix valve head (7) with internal hex. screws.
- Screw in and fasten stud (3).
- Put on gasket (2).
- Screw on acorn nut (1).

4.7. COMPRESSOR BLOCKS IK150 II mod. 10, IK15.1 II mod. 11, IK15.11 II mod. 1, IK180 II mod. 5, IK18.1 II mod. 4

4.7.1. Changing the valves of the 1st stage

Remove and reinstall the valves for replacement as follows (see Fig. 22).

Removal procedure

- Unscrew and remove nuts (6) and washers (5).
- Remove valve head assy (1) from studs in cylinder.
- To remove valve (2), unscrew and remove centre screw (4) and washer (3).

Installation procedure

- Fasten new valve with centre screw (4) and washer (3) to valve head (1).
- Place valve head assy on studs in cylinder.
- Tighten valve head with washers (5) and nuts (6) to correct torque values.

Workshop Manual

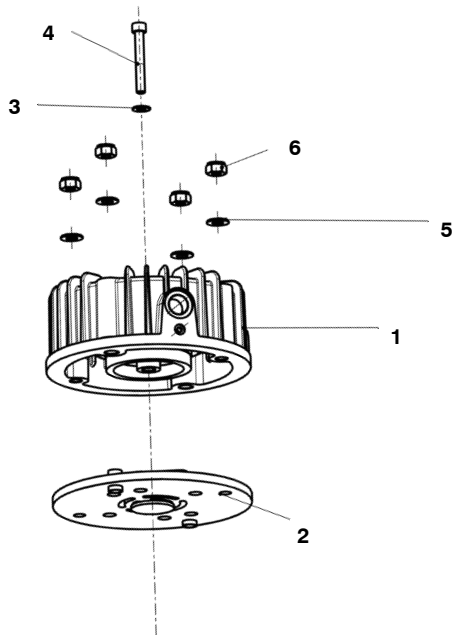

Fig. 28 Valve head and valves, 1st stage

- 1 Valve head
- 2 Plate valve
- 3 Gasket
- 4 Allen screw
- 5 Washer
- 6 Hex nut

4.7.2. Changing the valves of the 2nd and 3rd stages (IK18.1 3rd stage, only; 2nd stage see)

Remove and reinstall the valves for replacement as follows (see Fig. 23).

Removal procedure

- Unscrew and remove hex. nut (1). Remove cap holder (2).
- Insert two screwdrivers into the groove of the valve cap (3) and lift off valve cap with O-ring (4).
- Check, and if required, replace O-ring (4).
- Take out valves (5) and (6).
- Check valve gasket (7) and replace if required.

Installation procedure

- Fit new valve with gasket (7) and position valve cap (3) with O-ring (4).
- Fit cap holder (2).



The valve cap for the the inlet valve protrudes 2.5 mm (.98 in.) out of the valve head more than the valve cap for the discharge valve. (Cap holder is designed accordingly).

- Screw on hex. nut (1) and tighten with torque wrench. Refer to table in para. D-17.

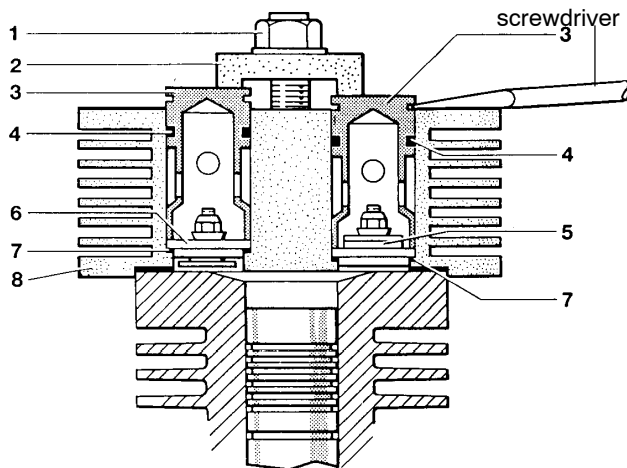

Fig. 29 Valve head and valves, 2nd/3rd stage

- 1 Hex. nut
- 2 Cap holder
- 3 Valve cap
- 4 O-ring
- 5 Discharge valve
- 6 Inlet valve
- 7 Valve gasket
- 8 Valve head

4.7.3. Changing the valves of the 2nd stage, IK18.1 II

Remove and reinstall the valves for replacement as follows (see Fig. 25).

Removal procedure

- Unscrew and remove hex. nut (1). Remove cap holder (2).
- Insert two screwdrivers into the groove of the valve cap (3) and lift off valve cap with O-ring (4).
- Check, and if required, replace O-ring (4).

Workshop Manual

- Take out valves (5) and (6).
- Check valve gasket (7) and replace if required.

Installation procedure

- Fit new valve with gasket (7) and position valve cap (3) with O-ring (4).
- Fit cap holder (2).



The valve cap for the the inlet valve protrudes 2.5 mm (.98 in.) out of the valve head more than the valve cap for the discharge valve. (Cap holder is designed accordingly).

- Screw on hex. nut (1) and tighten with torque wrench. Refer to table in chapter. 3.1.

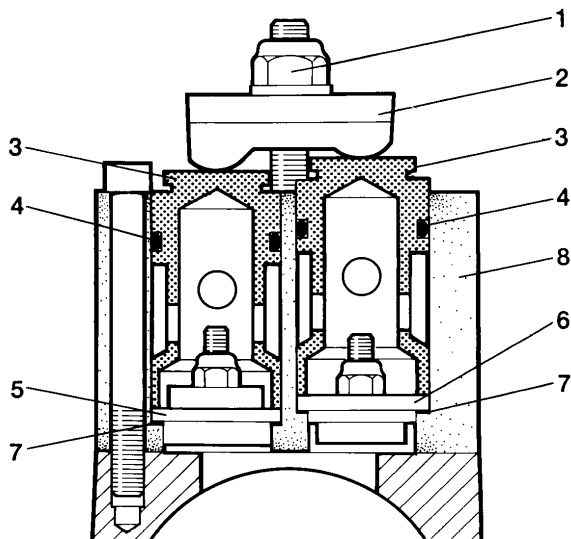

Fig. 30 Valve head and valves, 2nd stage IK18.1 II

- 1 Hex. nut
- 2 Cap holder
- 3 Valve cap
- 4 O-ring
- 5 Discharge valve
- 6 Inlet valve
- 7 Valve gasket
- 8 Valve head

4.7.4. Changing the valves of the 4th stage (4th and 5th stage on IK18.1 II)



Change intake and pressure valves together, only.

Removal of the intake valve:

- Insert two metal pins – 8 mm diameter, any length – in the holes in the cylinder head and secure these in a vice with the cylinder head on top.
- Unscrew the intake valve body with the special tool (part no. 4555–645, part of the tools set delivered with the unit) (Fig. 16).

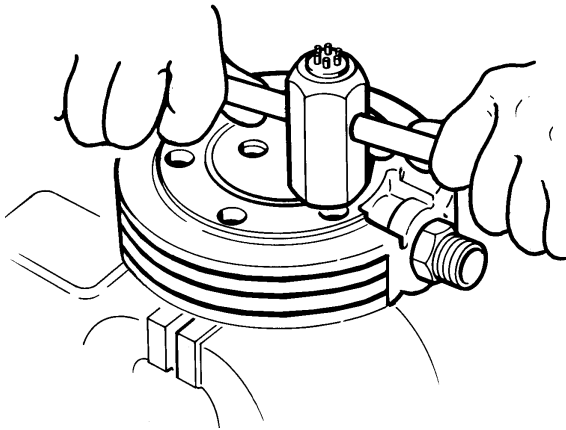

Fig. 31 Removing the intake valve



In order to avoid damaging the special tool or the valve when using the tool, ensure that it is pushed properly and firmly into the valve bore so that it will not tilt when it is turned.

Installation of the intake valve:

- Screw the intake valve in with the special tool and tighten.



Valve spring and valve plate must not be jammed.

Check valve function. To do so, blow compressed air through the valve in the direction of flow.

- Secure the intake valve as follows: Peen the cylinder head aluminium on the screw-in thread of the intake valve in two places opposite one another with a small drift pin, diameter approx. 5 mm (Fig. 19).

Workshop Manual

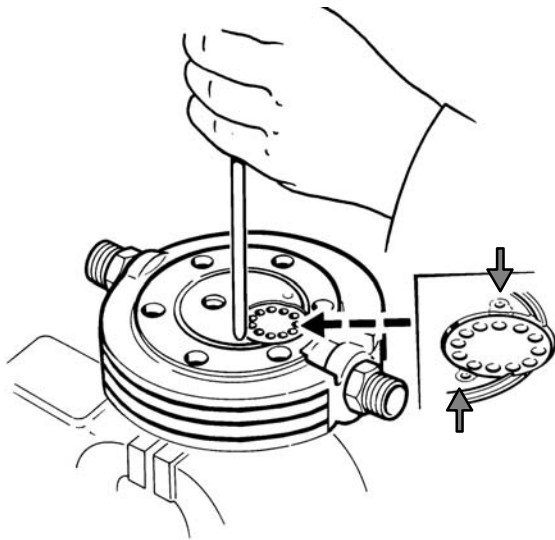

Fig. 32 Securing the intake valve

Removal and reinstallation of of the pressure valve (Fig. 20).

- Unscrew the intake and pressure lines from the cylinder head (7, Fig. 20).
- Remove acorn nut (1), rewind stud (3) up to three or four turns.
- Remove internal hex. screw (9) fixing valve head (7), take off valve head cover (8).
- Put two screwdrivers into the groove of outlet valve body, see Fig. 21. If necessary loosen valve first by using a 13 mm spanner on the flat surfaces.
- Lift out pressure valve (5) together with O-ring (4).

Reinstall pressure valve (5) in reverse sequence:

- Put O-ring (4) into valve head (7). Check O-ring for abrasions.
- Insert pressure valve (5). Put on valve head cover (8).
- Fix valve head (7) with internal hex. screws.
- Screw in and fasten stud (3).
- Put on gasket (2).
- Screw on acorn nut (1).

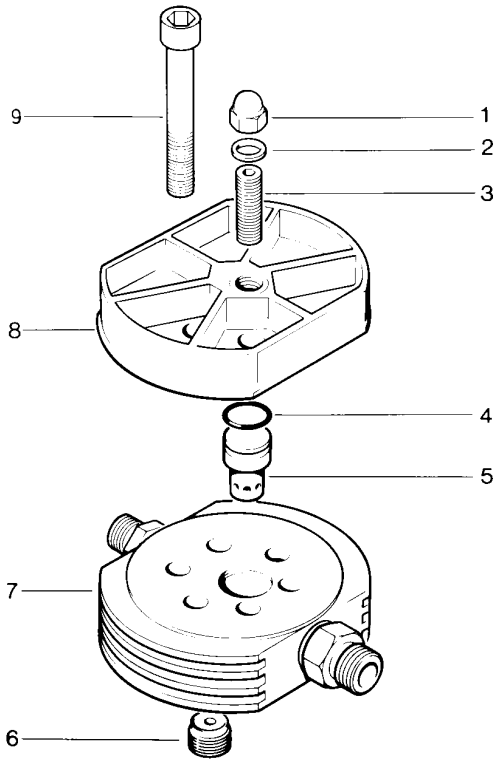

Fig. 33 Valve head 4th/5th stage

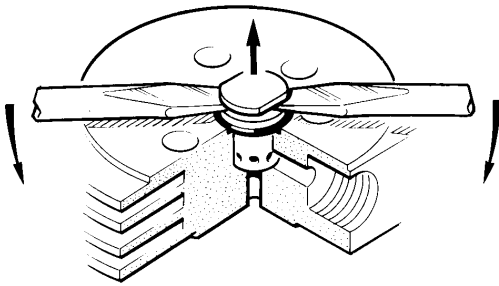

Fig. 34 Removal of 4th/5th stage pressure valve

Workshop Manual

4.8. COMPRESSOR BLOCK K22

4.8.1. Changing the valves of the 1st stage

The 1st stage valves are located in the valve head of the vertical 1st/2nd stage cylinder, see Fig. 35. One inlet and one discharge valve are provided.

Removal procedure

- Unscrew and remove cap nut (1).
- Unscrew stud (4) a number of turns.
- Check, and if required, replace gasket (3).
- Remove valve cover nuts (2) and take off valve cover (5).
- Check O–ring (11) and replace if required.
- Take off valve cap (6) and extract the valve.
- Check valve gasket (8) and replace, if required.

Installation procedure

- Fit new valve with gasket (8) and locate valve cap (6).
- Fit valve cover (5) with O–ring (11) and fasten with nuts (2).
- Tighten nuts diagonally using a torque wrench to the correct value.
- Tighten stud (4) using an allen key and screw on cap nut (1) and gasket (3).

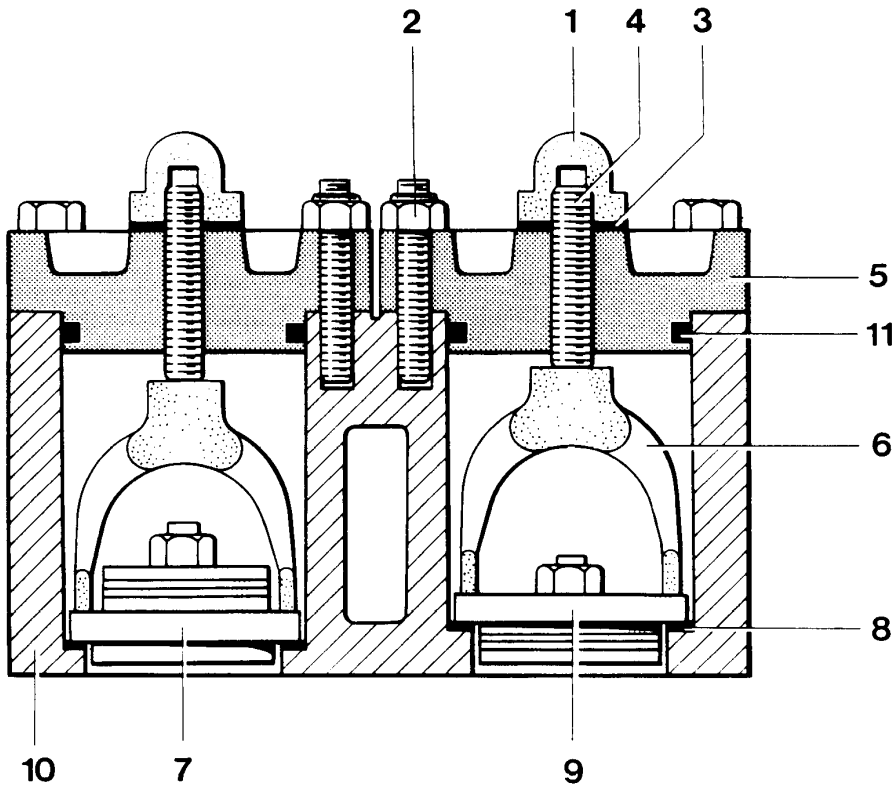

Fig. 35 Valve head and valves, 1st stage

- 1 Cap nut
- 2 Valve cover nut
- 3 Gasket
- 4 Stud
- 5 Valve cover
- 6 Valve cap
- 7 Discharge valve
- 8 Valve gasket
- 9 Inlet valve
- 10 Valve head
- 11 Valve cover gasket (O-ring)

Workshop Manual

4.8.2. Changing the valves of the 2nd stage

The 2nd stage valves are located directly on the side of the 1st/2nd stage cylinder, Fig. 36. One inlet and one discharge valve are provided.

The 2nd stage valves are removed and reinstalled in the same way as for the 1st stage.

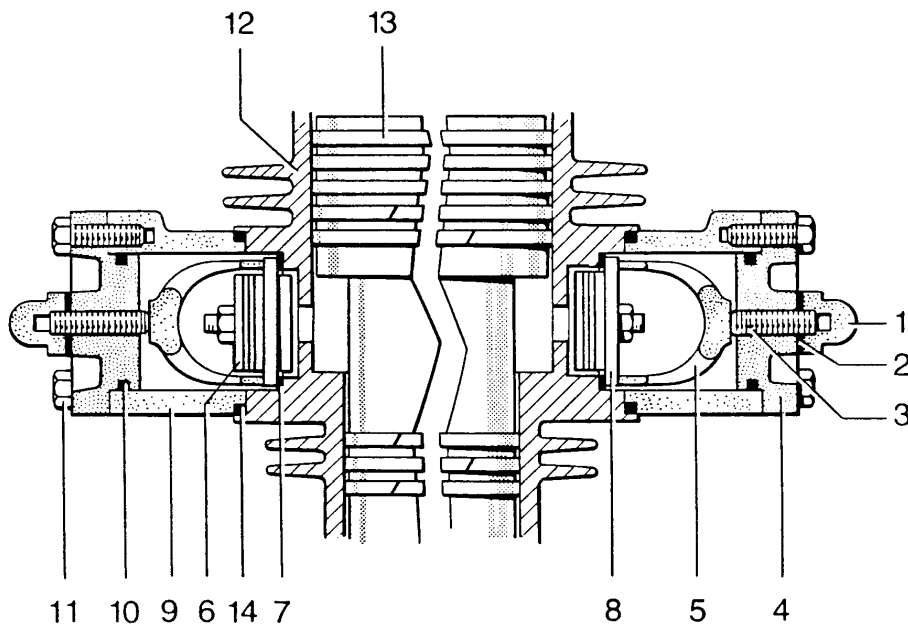

Fig. 36 Cylinder, 1st/2nd stage with 2nd stage valves

- 1 Cap nut
- 2 Gasket
- 3 Stud
- 4 Valve cover
- 5 Valve cap
- 6 Discharge valve
- 7 Valve gasket
- 8 Inlet valve
- 9 Inlet / discharge manifold
- 10 Valve cover gasket (O-ring)
- 11 Valve cover bolt
- 12 1st/2nd stage cylinder
- 13 1st/2nd stage piston
- 14 Gasket

4.8.3. Changing the valves of the 3rd stage

The 3rd stage valves are located in the valve head of the 3rd stage, Fig. 37. One inlet and one discharge valve are provided.

Remove and reinstall valves as follows:

Removal procedure

- Unscrew and remove hex. nuts (1) and remove cap holder (2).
- Insert two screwdrivers into the groove of the valve cap (3) and lift out valve cap with O-ring (4).
- Pull out valve.
- Check valve gasket (7) and replace if required.
- Check O-ring (4) and replace if required.
- Clean valve and check function.
- Replace any faulty parts.

Installation procedure

- Fit new valve with gasket (7) and locate valve cap (3) with O-rings (4).
- Fit cap holder (2).



The valve cap of the the inlet valve protrudes 2.5 mm (.098 in.) more out of the valve head than the valve cap for the discharge valve. The cap holder is designed accordingly.

Workshop Manual

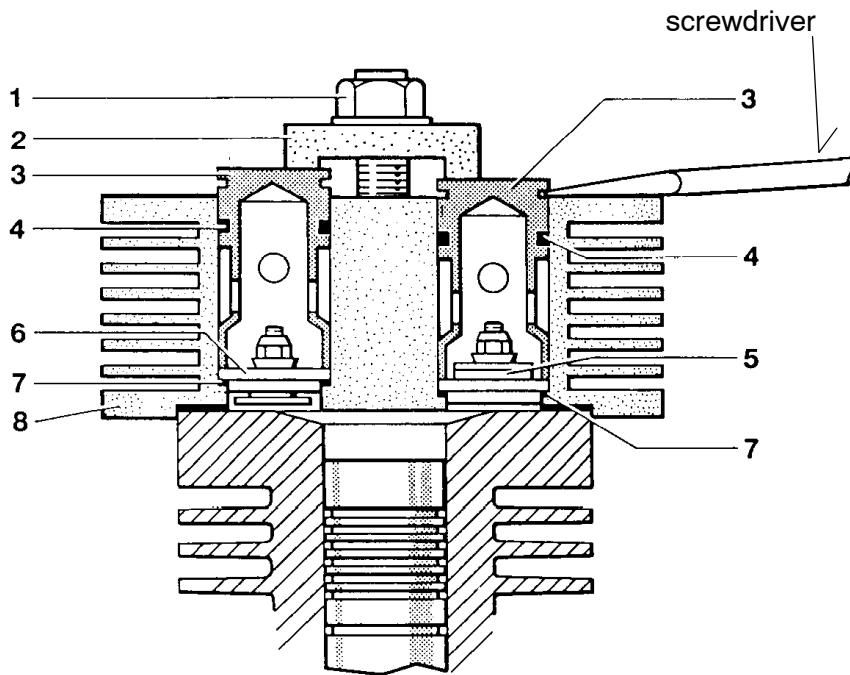

Fig. 37 Valve head and valves, 3rd stage

- Screw on hex. nut (1) and tighten with torque wrench.

4.8.4. Changing the valves of the 4th stage

The valves are located in the valve head of the 4th stage, see Fig. 38. The inlet valve merely comprises a valve disk (6) and a wavy washer (5). The inlet valve seat is machined directly into the cylinder liner (8) of the 4th stage piston. The discharge valve consists of the valve seat (11), valve disk (12), valve spring (13), and stroke limiter (2).

The valve head comprises the bottom section (7) and the upper section (3). The valve head is secured by means of the valve head screw (14) connecting the cylinder.

The procedure for removal and reinstallation of the valves is as follows:

Removal procedure

- Loosen the inlet and discharge pipe on the valve head.
- Loosen and remove valve head screw (14).
- Take off valve top section (3) and stroke limiter (2) with O-ring (1). This releases the discharge valve disk (12) and discharge valve spring (13).
- Check spring for satisfactory condition and resiliency preferably by comparing with a new spring.
- Replace spring if necessary.
- Check O-ring (1) and replace if necessary.
- Insert two screwdrivers into the extraction groove (4) of the discharge valve seat (11) and lift valve seat with O-ring (9).
- Check, and if required, replace O-ring (9) and backing ring (10).
- Remove wavy washer (5) and inlet valve disk (6).
- Check inlet valve seat on piston liner (8). If scored, remove piston liner, take out piston, and lap valve seat.

Installation procedure

- Turn flywheel on compressor manually until piston protrudes from the cylinder liner (8).
- Locate the inlet valve disk (6) and the wavy washer (5), both of which are prevented from side slip by the piston.
- Insert the discharge valve seat (11) in the bottom section of the valve head (7), taking care to avoid damaging the inlet valve disk and wavy washer.
- Place discharge valve spring (13) and discharge valve disk (12) on stroke limiter (2) and locate this in the top section of the valve head.
- Screw in valve head screws (14) and tighten down diagonally using a torque wrench.

Workshop Manual

- Tighten inlet and discharge pipe couplings.

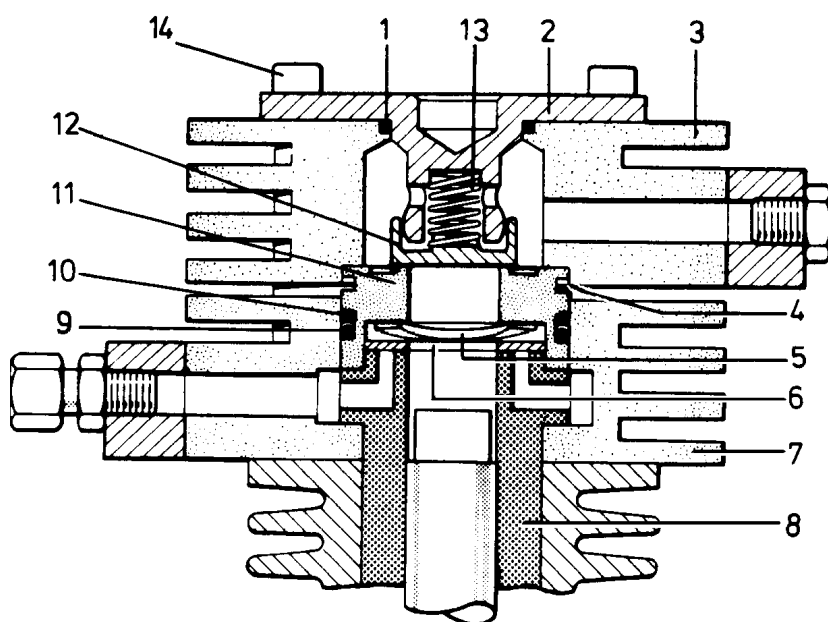

Fig. 38 Valve head and valves, 4th stage

- 1 O-ring
- 2 Stroke limiter
- 3 Valve head, top section
- 4 Extraction groove
- 5 Wavy washer
- 6 Inlet valve disk
- 7 Valve head, bottom section
- 8 Piston liner
- 9 O-ring
- 10 Backing ring
- 11 Discharge valve seat
- 12 Discharge valve disk
- 13 Discharge valve spring
- 14 Valve head screw

4.9. COMPRESSOR BLOCK K23

4.9.1. Changing the valves of the 1st stage

The 1st stage valves are located in the vertical 1st/2nd stage cylinder, see Fig. 39. Two inlet and two discharge valves are provided.

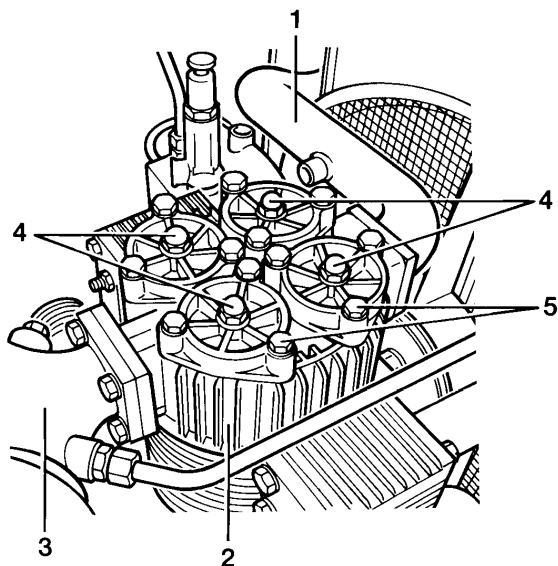

Fig. 39 Valve head, 1st stage

- 1 Discharge line
- 2 Valve head
- 3 Intake port
- 4 Cap nut
- 5 Valve cover bolts

Remove and reinstall the valves as follows:

Removal procedure (see Fig. 40)

- Unscrew and remove cap nut (1).
- Check, and if required, replace gasket (3).
- Unscrew stud (4) a number of turns.
- Remove valve cover nuts (2) and take off valve cover (5).
- Check O-ring (11) and replace if necessary.
- Take off valve cap (6) and take out the valve.
- Check the valve gasket (8) and replace if necessary.

Workshop Manual

Installation procedure

- Fit new valve with gasket (8) and locate valve cap (6).
- Fit valve cover (5) with O-ring (11) and fasten with bolts (2).
- Tighten bolts diagonally using a torque wrench to the correct value.
- Tighten stud (4) using an allen key and screw on cap nut (1).

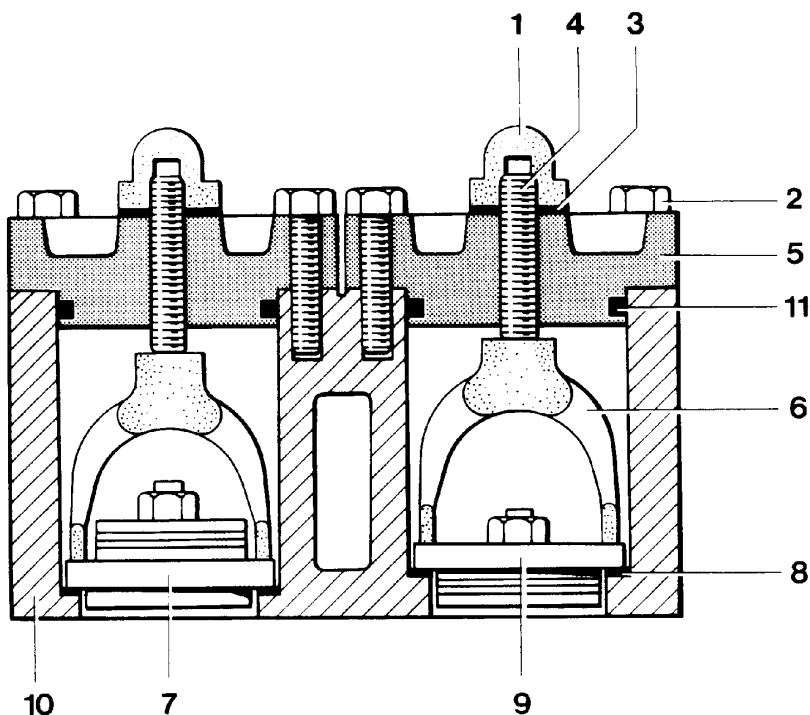

Fig. 40 Valves, 1st stage

- 1 Cap nut
- 2 Valve cover bolt
- 3 Gasket
- 4 Stud
- 5 Valve cover
- 6 Valve cap
- 7 Discharge valve
- 8 Valve gasket
- 9 Inlet valve
- 10 Valve head
- 11 Valve cover gasket (O-ring)

4.9.2. Changing the valves of the 2nd stage

- The 2nd stage valves are located directly on the side of the 1st/2nd stage cylinder, Fig. 41. One inlet and one outlet valve are provided.

Remove and reinstall the valves as follows:

Removal procedure (see Fig. 42)

- Unscrew and remove cap nut (12).
- Check gasket (11) and replace if necessary.
- Unscrew stud (10) a number of turns.
- Remove valve cover bolt (9) and take off valve cover (8).
- Check O-ring (7) and replace if necessary.
- Remove valve cap (4) and take out valve.
- Check valve gasket (13) and replace if necessary.

Installation procedure

- Fit new valves with gaskets (13) and locate valve cap (4).
- Fit valve cover (8) with O-ring (7) and fasten with bolts (9). Tighten bolts diagonally using a torque wrench to the correct value.
- Tighten stud (10) using an allen key and screw on cap nut (12) with gasket (11).

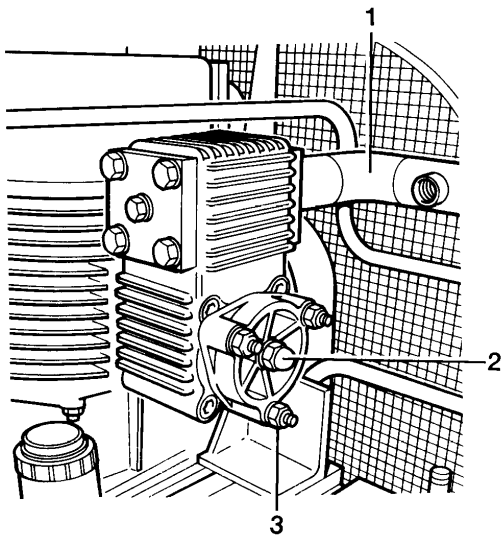

Fig. 41 2nd stage valve head

- 1 Discharge line
- 2 Cap nut
- 3 Valve cover nut

Workshop Manual

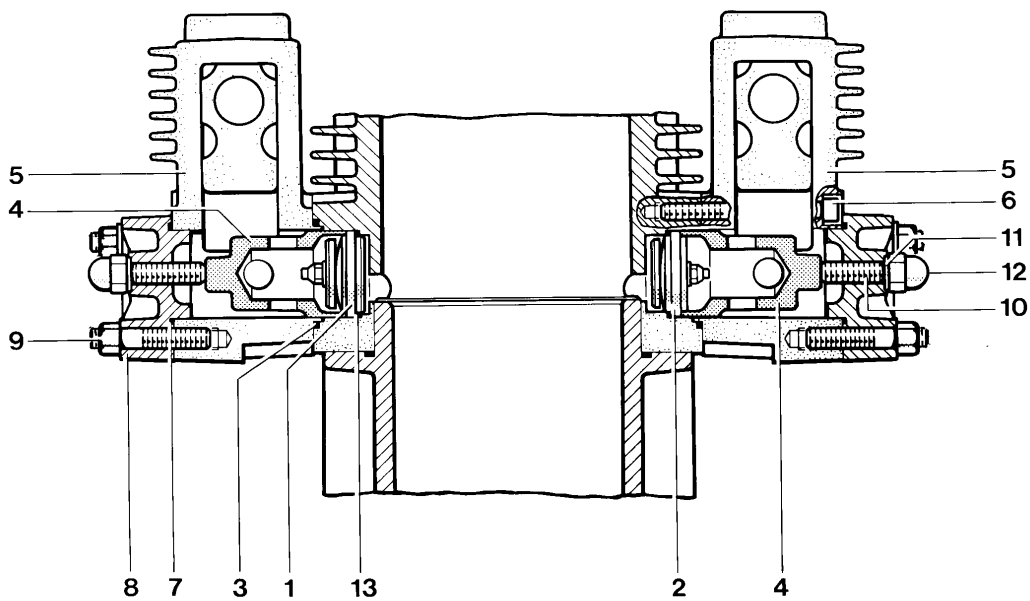

Fig. 42 2nd stage valves

- 1 Discharge valve
- 2 Intake valve
- 3 O-ring
- 4 Valve cap
- 5 Manifold
- 6 Allen screw
- 7 O-ring
- 8 Valve cover
- 9 Nut
- 10 Stud
- 11 Gasket
- 12 Cap nut
- 13 Valve gasket

4.9.3. Changing the valves of the 3rd stage

The 3rd stage valves are located in the horizontally positioned 3rd stage valve head. One inlet and one outlet valve are provided.

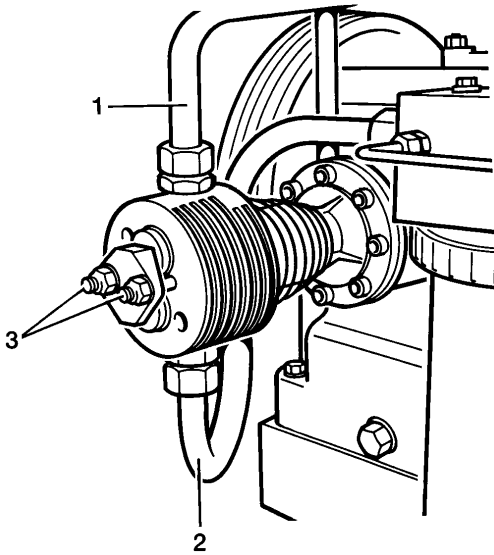

Fig. 43 Cylinder, 3rd stage and valve head
 1 Intake line
 2 Discharge line
 3 Securing nuts for press pad

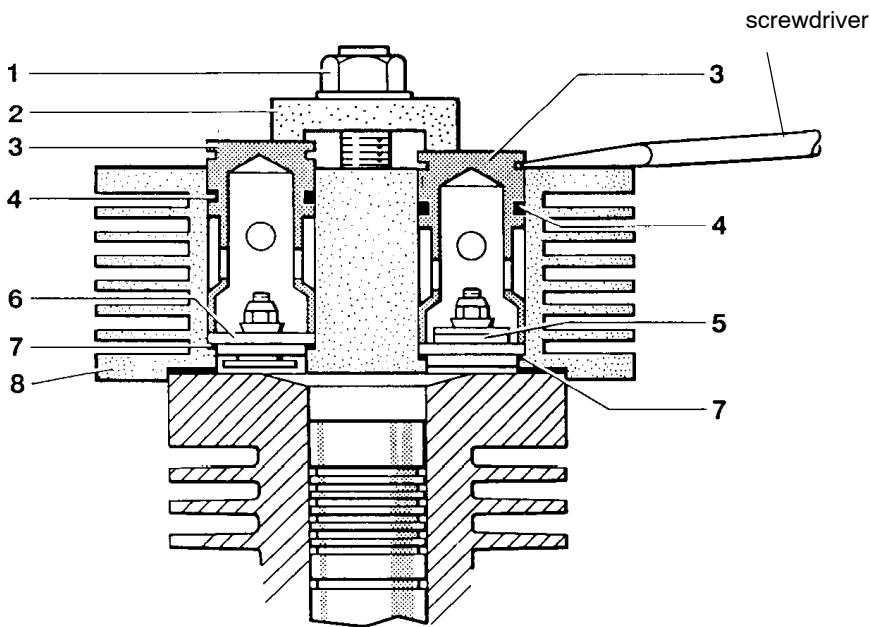

Fig. 44 Valve head and valves, 3rd stage

The valves are removed and reinstalled as follows (Fig. 44):

Workshop Manual

Removal procedure

- Unscrew and remove hex. nut (1) and remove cap holder (2).
- Insert two screwdrivers into the groove of the valve cap (3) and lift out valve cap with O-ring (4).
- Pull out valves (5) and (6).
- Check valve gaskets (7) and replace if required.
- Check O-rings (4) and replace if required.

Installation procedure

- Fit new valves with gaskets (7) and locate valve caps (3) with O-rings (4).
- Fit cap holder (2).



The valve cap of the the inlet valve protrudes 2.5 mm (.098 in.) more out of the valve head than the valve cap for the discharge valve. The cap holder is designed accordingly.

- Screw on hex. nut (1) and tighten with torque wrench. Refer to table in chapter 3.1.

4.9.4. Changing the valves of the 4th stage

The 4th stage valves are located in the 4th stage valve head, Fig. 45.

The inlet valve merely comprises a valve disk (6, Fig. 46) and a wavy washer (5). The inlet valve seat is machined directly into the cylinder liner (8) of the 4th stage piston. The discharge valve consists of the valve seat (11), valve disk (12), valve spring (13), and stroke limiter (2).

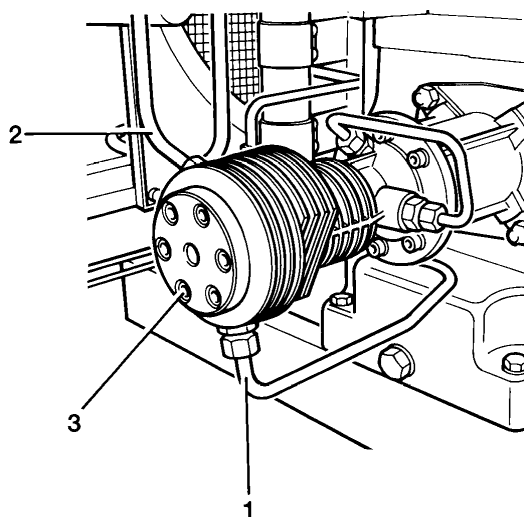

Fig. 45 Cylinder and valve head, 4th stage

The valve head comprises the bottom section (7) and the upper section (3). The valve head is secured by means of the valve head screw (14) connecting the cylinder.

The procedure for removal and reinstallation of the valves is as follows (see Fig. 46):

Removal procedure

- Loosen the inlet and discharge pipe on the valve head (1 and 2, Fig. 45).
- Loosen and remove valve head screw (3, Fig. 45; 14, Fig. 46).

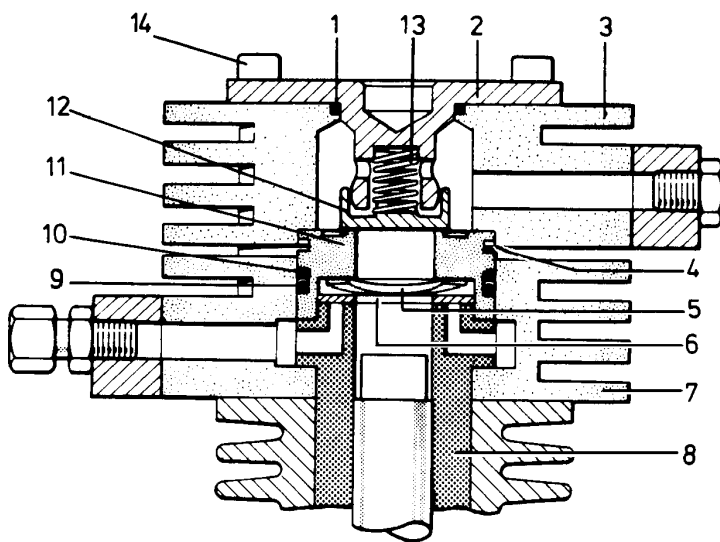

Fig. 46 Valve head and valves, 4th stage

- 1 O-ring
- 2 Stroke limiter
- 3 Valve head, top section
- 4 Extraction groove
- 5 Wavy washer
- 6 Inlet valve disk
- 7 Valve head, bottom section
- 8 Piston liner
- 9 O-ring
- 10 Backing ring
- 11 Discharge valve seat
- 12 Discharge valve disk
- 13 Discharge valve spring
- 14 Valve head screw

- Take off valve top section (3) and stroke limiter (2) with O-ring (1). This releases the discharge valve disk (12) and discharge valve spring (13).
- Check spring for satisfactory condition and resiliency preferably by comparing with a new spring.

Workshop Manual

- Replace spring if necessary.
- Check O–ring (1) and replace if necessary.
- Insert two screwdrivers into the extraction groove (4) of the discharge valve seat (11) and lift valve seat with O–ring (9).
- Check, and if required, replace O–ring (9) and backing ring (10).
- Remove wavy washer (5) and inlet valve disk (6).
- Check inlet valve seat on piston liner (8). If scored, remove piston liner, take out piston, and lap valve seat.

Installation procedure

Turn flywheel on compressor manually until piston protrudes from the cylinder liner (8).

Locate the inlet valve disk (6) and the wavy washer (5), both of which are prevented from side slip by the piston.

Insert the discharge valve seat (11) in the bottom section of the valve head (7), taking care to avoid damage to the inlet valve disk and wavy washer.

Place discharge valve spring (13) and discharge valve disk (12) on stroke limiter (2) and locate this in the top section of the valve head. Position the top section of the valve head on the bottom section.

Screw in valve head screws (14) and tighten down diagonally using a torque wrench.

Tighten inlet and discharge pipe couplings.

4.10. COMPRESSOR BLOCKS K25, K28

4.10.1. Changing the valves of the 1st stage

The 1st stage valves are located in the valve head of the 1st/2nd stage vertical cylinder, see Fig. 47. One inlet and one outlet valve are provided.

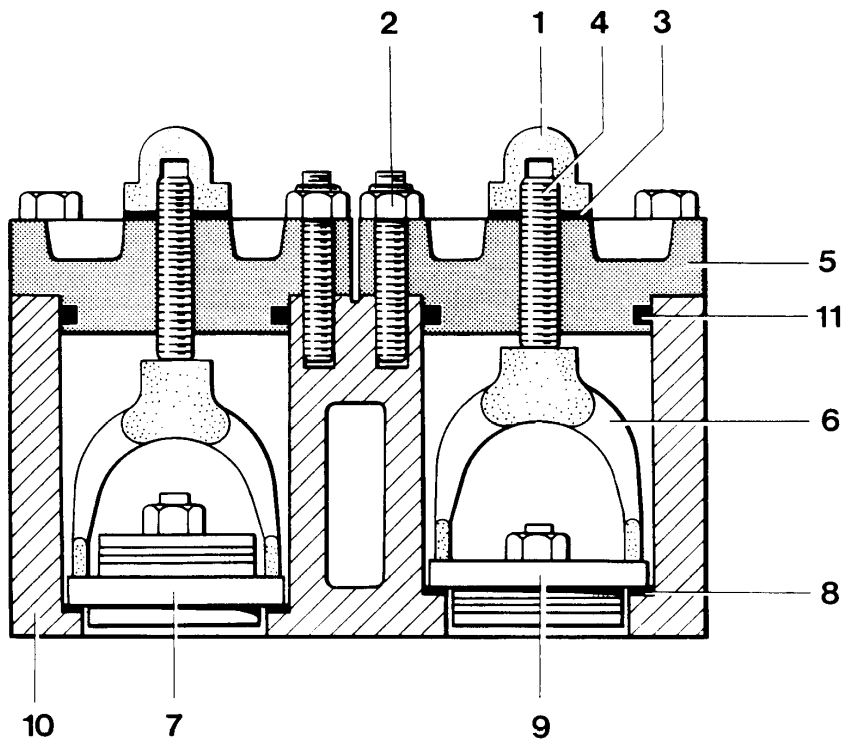

Fig. 47 Valve head and valves, 1st stage

- 1 Cap nut
- 2 Valve cover nut
- 3 Gasket
- 4 Stud
- 5 Valve cover
- 6 Valve cap
- 7 Discharge valve
- 8 Valve gasket
- 9 Inlet valve
- 10 Valve head
- 11 Valve cover gasket (O-ring)

Remove and reinstall valves as follows:

Workshop Manual

Removal procedure

- Unscrew and remove cap nut (1).
- Unscrew stud (4) a number of turns.
- Check, and if required, replace gasket (3).
- Remove valve cover nuts (2) and take off valve cover (5).
- Check O–ring (11) and replace if required.
- Take off valve cap (6) and extract the valve.
- Check valve gasket (8) and replace, if required.

Installation procedure

- Fit new valve with gasket (8) and locate valve cap (6).
- Fit valve cover (5) with O–ring (11) and fasten with nuts (2).

Tighten nuts diagonally using a torque wrench to the correct value.

Tighten stud (4) using an allen key and screw on cap nut (1) and gasket (3).

4.10.2. Changing the valves of the 2nd stage

The 2nd stage valves are located directly on the side of the 1st/2nd stage cylinder, Fig. 48. One inlet and one outlet valve are provided.

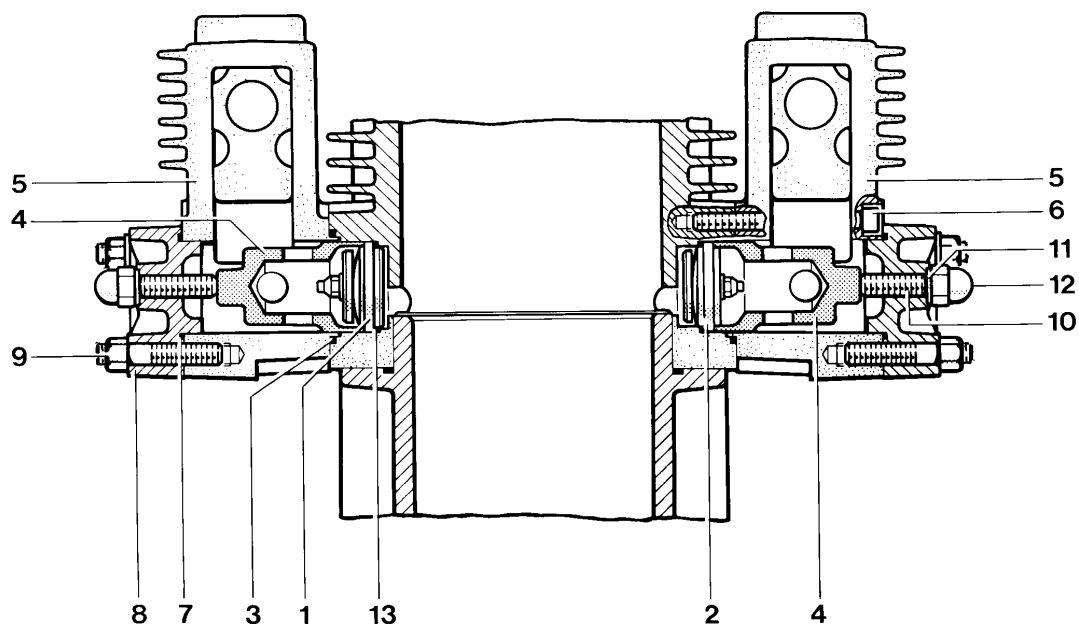

Fig. 48 Valve head and valves, 2nd stage

- 1 Discharge valve
- 2 Intake valve
- 3 O-ring
- 4 Valve cap
- 5 Manifold
- 6 Allen screw
- 7 O-ring
- 8 Valve cover
- 9 Nut
- 10 Stud
- 11 Gasket
- 12 Cap nut
- 13 Valve gasket

The 2nd stage valves are removed and reinstalled as follows:

Removal procedure

- Remove cap nut (12).
- Check gasket (11) and replace if necessary.
- Unscrew stud (10) a number of turns.
- Remove nuts (9) and take off valve cover.
- Check O-ring (7) and replace if necessary.

Workshop Manual

- Remove valve cap (4) and take out valve.
- Check valve gasket (13) and replace if necessary.

Installation procedure

- Fit new valve with gasket (13) and locate valve cap (4).
- Fit valve cover (8) with O-ring (7) and fasten with nuts (9). Tighten nuts diagonally using a torque wrench to the correct value. Refer to table in chapter 3.1.
- Tighten stud (10) using an allen key and screw on cap nut (12) with gasket (11).

4.10.3. Changing the valves of the 3rd stage

The 3rd stage valves are located in the 3rd stage valve head, Fig. 49. Two inlet and two outlet valves are provided.

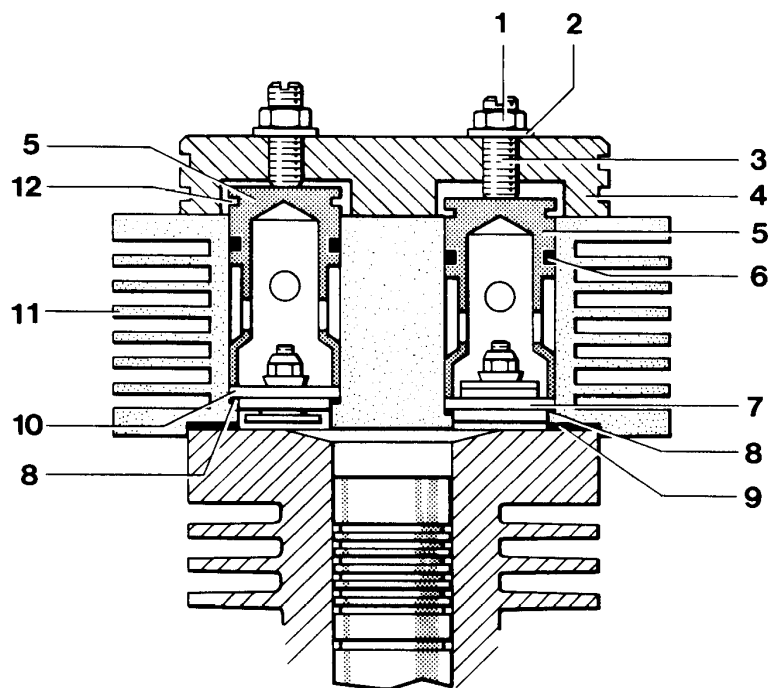

Fig. 49 Valve head and valves, 3rd stage

- 1 Hex. nut
- 2 Lock washer
- 3 Stud
- 4 Valve cover
- 5 Valve cap
- 6 O-ring
- 7 Discharge valve
- 8 Gasket
- 9 Valve head gasket
- 10 Inlet valve
- 11 Valve head
- 12 Groove

Removal procedure

- Unscrew and remove hex. nuts (1).
- Loosen studs (3) a couple of turns.
- Remove six allen screws (not shown) from valve head cover and remove valve cover (4).
- Insert two screwdrivers into groove (12) of the valve cap (5) and lift out valve cap with O-ring (6).
- Check O-ring (6) and replace if required.
- Pull out valves (7) and (10).

Workshop Manual

Inspection

- Check valve gasket (8) and replace if required.
- Clean valves and check function.
- Replace any faulty parts.

Installation procedure

- Fit new valves with gaskets (8) and locate valve caps (5) with O-rings (6).
- Fit valve cover (4) and secure with six allen screws.



The valve cap of the the inlet valve protrudes 3 mm (0.118 in.) more out of the valve head than the valve cap for the discharge valve. Make sure that studs are turned out far enough before installing valve cover.

- Tighten studs (3) by hand.
- Screw on hex. nut (1) and tighten with torque wrench while holding studs in position with a screw-driver.

4.10.4. Changing the valves of the 4th stage

The valves are located in the valve head of the 4th stage, see Fig. 50. The inlet valve merely comprises a valve disk (6) and a wavy washer (5). The inlet valve seat is machined directly into the cylinder liner (8) of the 4th stage piston. The discharge valve consists of the valve seat (11), valve disk (12), valve spring (13), and stroke limiter (2).

The valve head comprises the bottom section (7) and the upper section (3). The valve head is secured to the cylinder by means of the valve head screw (14).

The procedure for removal and reinstallation of the valves is as follows:

Removal procedure

- Loosen the inlet and discharge pipe on the valve head.
- Loosen and remove valve head screw (14).
- Take off valve top section (3) and stroke limiter (2) with O-ring (1). This releases the discharge valve disk (12) and discharge valve spring (13).
- Check spring for satisfactory condition and resiliency preferably by comparing with a new spring.
- Replace spring if necessary.
- Check O-ring (1) and replace if necessary.

- Insert two screwdrivers into the extraction groove of the discharge valve seat (11) and lift valve seat with O-ring (9).
- Check, and if required, replace O-ring (9) and backing ring (10).
- Remove wavy washer (5) and inlet valve disk (6).
- Check inlet valve seat on piston liner (8). If scored, remove piston liner, take out piston and lap valve seat.

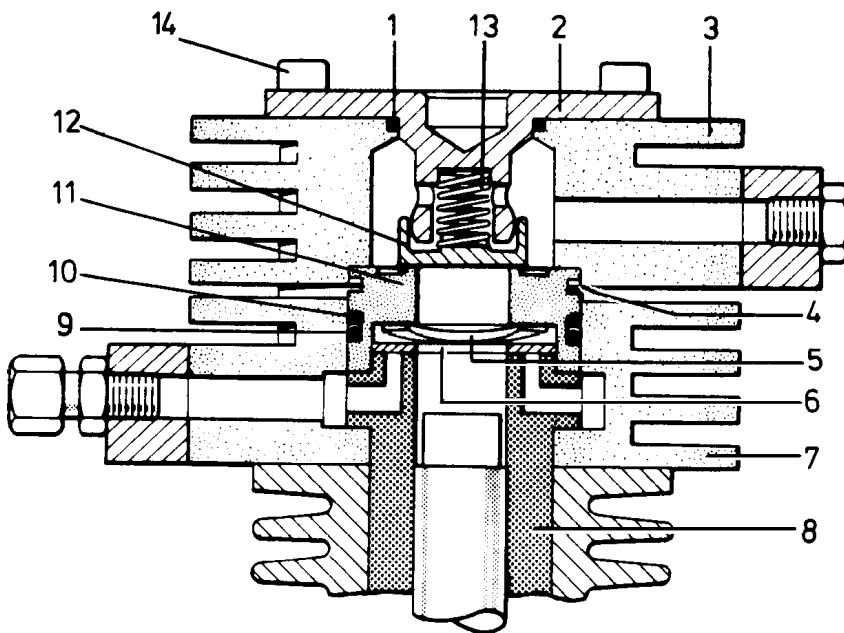

Fig. 50 Valve head and valves, 4th stage

- 1 O-ring
- 2 Stroke limiter
- 3 Valve head, top section
- 4 Extraction groove
- 5 Wavy washer
- 6 Inlet valve disk
- 7 Valve head, bottom section
- 8 Piston liner
- 9 O-ring
- 10 Backing ring
- 11 Discharge valve seat
- 12 Discharge valve disk
- 13 Discharge valve spring
- 14 Valve head screw

Workshop Manual

Installation procedure

- Turn flywheel on compressor manually until piston protrudes from the cylinder liner (8).
- Locate the inlet valve disk (6) and the wavy washer (5), both of which are prevented from side slip by the piston.
- Insert the discharge valve seat (11) in the bottom section of the valve head (7), taking care to avoid damaging the inlet valve disk and wavy washer.
- Place discharge valve spring (13) and discharge valve disk (12) on stroke limiter (2) and locate this in the top section of the valve head. Place the top section of the valve head on the bottom section.
- Screw in valve head screws (14) and tighten down diagonally using a torque wrench.
- Tighten inlet and discharge pipe couplings.

4.11. KOMPRESSORBLOCK IK22.2

4.11.1. Changing the valves of the 1st stage

The 1st stage valves are located in the valve head of the 1st stage. One inlet and one discharge valve are provided.

Remove and reinstall the valves for replacement as follows (see Fig. 51).

Removal procedure

- Unscrew and remove cap nut (1).
- Unscrew stud (4) a number of turns.
- Check, and if required, replace gasket (3).
- Remove valve cover nuts (2) and take off valve cover (5).
- Check O-ring (11) and replace if required.
- Take off valve cap (6) and extract the valve.
- Check valve gasket (8) and replace, if required.

Workshop Manual

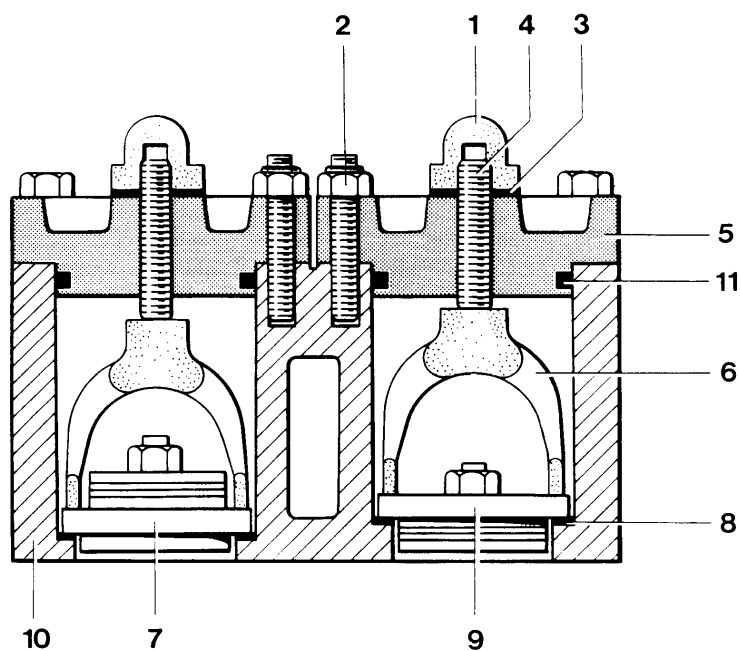

Fig. 51 Valve head and valves, 1st stage

- 1 Cap nut
- 2 Valve cover nut
- 3 Gasket
- 4 Stud
- 5 Valve cover
- 6 Valve cap
- 7 Discharge valve
- 8 Valve gasket
- 9 Inlet valve
- 10 Valve head
- 11 Valve cover gasket (O-ring)

Installation procedure

- Fit new valve with gasket (8) and locate valve cap (6).
- Fit valve cover (5) with O-ring (11) and fasten with nuts (2).
- Tighten nuts diagonally using a torque wrench to the correct value.
- Tighten stud (4) using an allen key and screw on cap nut (1) and gasket (3).

4.11.2. Changing the valves of the 2nd stage

The 2nd stage valves are located in the valve head of the 2nd stage cylinder. One inlet and one discharge valve are provided (Fig. 52).

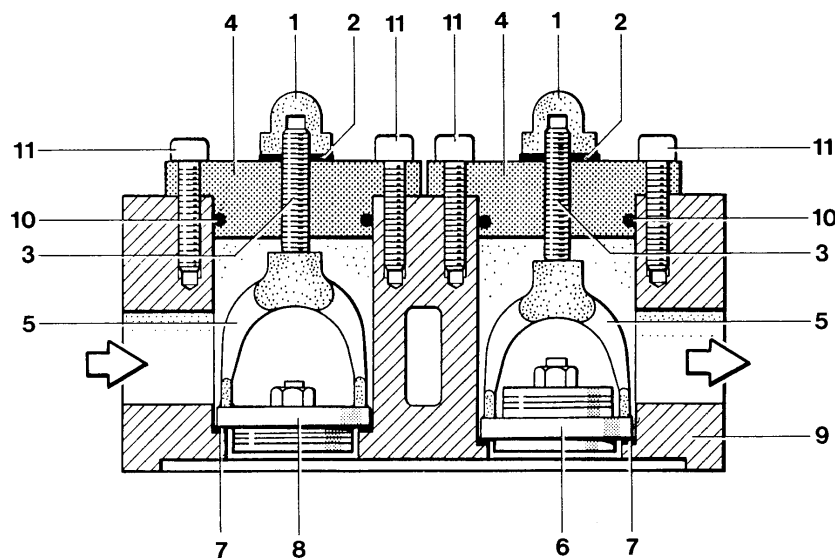

Fig. 52 Valve head and valves, 2nd stage

- 1 Cap nut
- 2 Gasket
- 3 Stud
- 4 Valve cover
- 5 Valve cap
- 6 Discharge valve
- 7 Valve gasket
- 8 Inlet valve
- 9 Inlet / discharge manifold
- 10 Valve cover gasket (O-ring)
- 11 Valve cover bolt

Removal procedure

- Unscrew and remove cap nut (1).
- Check, and if required, replace gasket (2).
- Unscrew stud (3) a number of turns.
- Remove valve cover bolts (11) and take off valve cover (4).
- Check O-ring (10) and replace if required.

Workshop Manual

- Take off valve cap (5) and extract the valve.
- Check valve gasket (7) and replace, if required.

Installation procedure

- Fit new valve with gasket (7) and locate valve cap (5).
- Fit valve cover (4) with O-ring (10) and fasten with bolts (11).
- Tighten bolts diagonally using a torque wrench to the correct value.
- Tighten stud (3) using an allen key and screw on cap nut (1) with gasket (2).

4.12. COMPRESSOR BLOCK IK22.5

4.12.1. Changing the valves of the 1st stage

The valves of the 1st stage are located in the valve head of the first (vertical) stage. One inlet and one discharge valve are provided. For removal and reinstallation of the valves, see 4.11.1.

4.12.2. Changing the valves of the 2nd stage

The valves of the 2nd stage are located in the valve head of the 2nd stage cylinder (left). One inlet and one discharge valve are provided. Use the same procedure as for the valves of the 1st stage. Refer to 4.11.1.

4.12.3. Changing the valves of the 3rd stage

The 3rd stage valves are located in the valve head of the 3rd stage. One inlet and one discharge valve are provided (Fig. 53).

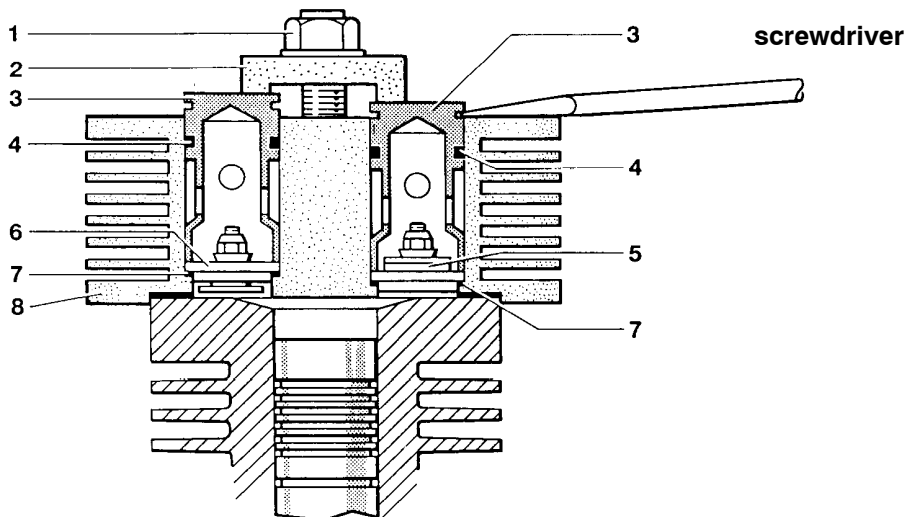

Fig. 53 Valve head and valves, 3rd stage

- 1 Hex. nut
- 2 Cap holder
- 3 Valve cap
- 4 O-ring
- 5 Discharge valve
- 6 Intake valve
- 7 Valve gasket
- 8 Valve head

Workshop Manual

Removal procedure

- Unscrew and remove hex. nuts (1) and remove cap holder (2).
- Insert two screwdrivers into the groove of the valve cap (3) and lift out valve cap with O–ring (4).
- Pull out valves (5) and (6).

Inspection

- Check valve gaskets (7) and replace if required.
- Check O–rings (4) and replace if required.
- Clean valves and check function.
- Replace any faulty parts.

Installation procedure

- Fit new valves with gaskets (7) and locate valve caps (3) with O–rings (4).
- Fit cap holder (2).



The valve cap of the the inlet valve protrudes 2.5 mm (.098 in.) more out of the valve head than the valve cap for the discharge valve. The cap holder is designed accordingly.

- Screw on hex. nut (1) and tighten with torque wrench.

4.13. COMPRESSOR BLOCK IK23.4

4.13.1. Changing the valves of the 1st stage

The 1st stage valves are located in the valve head on the two horizontal 1st stage cylinders. One inlet and discharge valve are provided for each cylinder.

For removal and reinstallation of the valves, see 4.11.1.

4.13.2. Changing the valves of the 2nd stage

The 2nd stage valves are located directly on the side of the vertical 2nd/3rd stage cylinder. One inlet and one discharge valve are provided (Fig. 54).

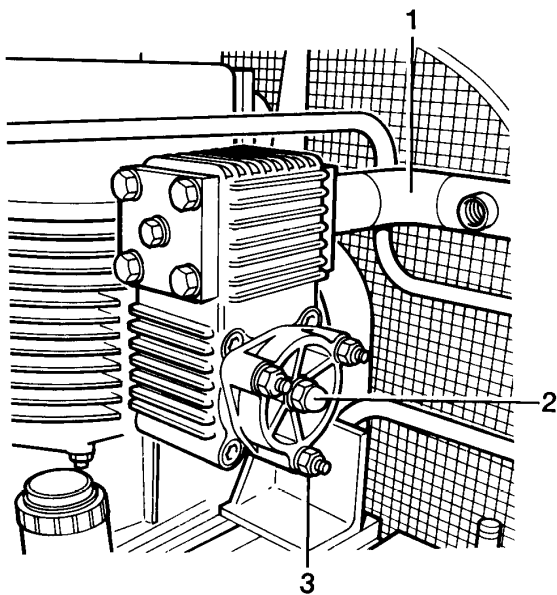

Fig. 54 Cylinder head 2nd/3rd stage with valve head 2nd stage

- 1 Pressure line
- 2 Cap nut
- 3 Valve cover nut

Remove and reinstall valves as follows:

Removal procedure (see Fig. 55)

- Unscrew and remove cap nut (12).
- Check and if required replace gasket (11).
- Unscrew stud (10) a number of turns.

Workshop Manual

- Remove valve cover bolts (9) and take off valve cover (8).
- Check O-ring (7) and replace if required.
- Take off valve cap (4) and extract the valve.
- Check valve gasket (13) and replace if required.

Installation procedure

- Fit new valve with gasket (13) and locate valve cap (4).
- Fit valve cover (8) with O-ring (7) and fasten with bolts (9). Tighten bolts diagonally using a torque wrench to the correct value.
- Tighten stud (10) using an allen key and screw on cap nut (12) with gasket (11).

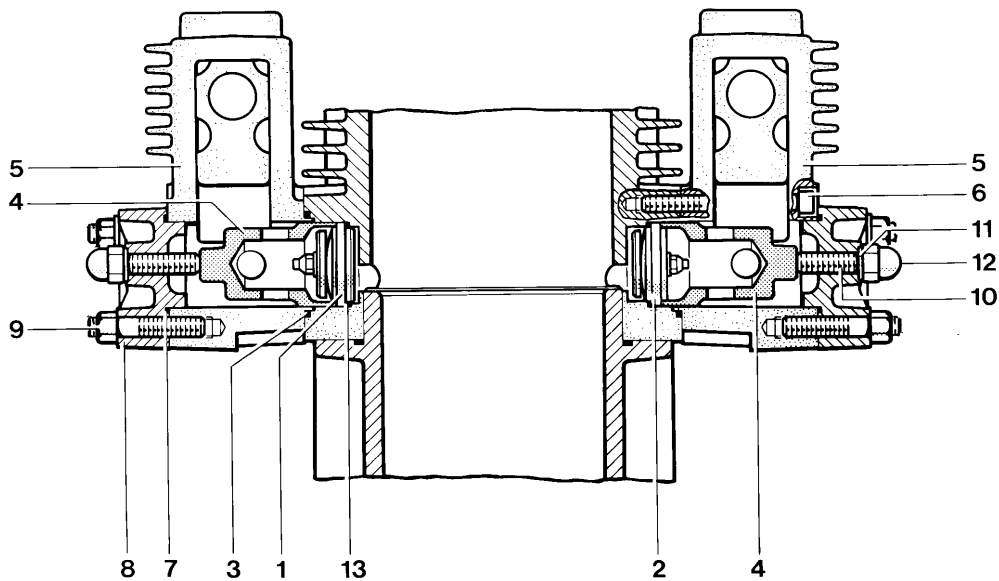

Fig. 55 Cylinder 1st/2nd stage with 2nd stage valves

- 1 Discharge valve
- 2 Intake valve
- 3 O-ring
- 4 Valve cap
- 5 Inlet / discharge manifold
- 6 Allen screw
- 7 O-ring
- 8 Valve cover
- 9 Valve cover nut
- 10 Stud
- 11 Gasket
- 12 Cap nut
- 13 Valve gasket

4.13.3. Changing the valves of the 3rd stage

The 3rd stage valves are located in the valve head of the 3rd stage. Two inlet and two discharge valves are provided.

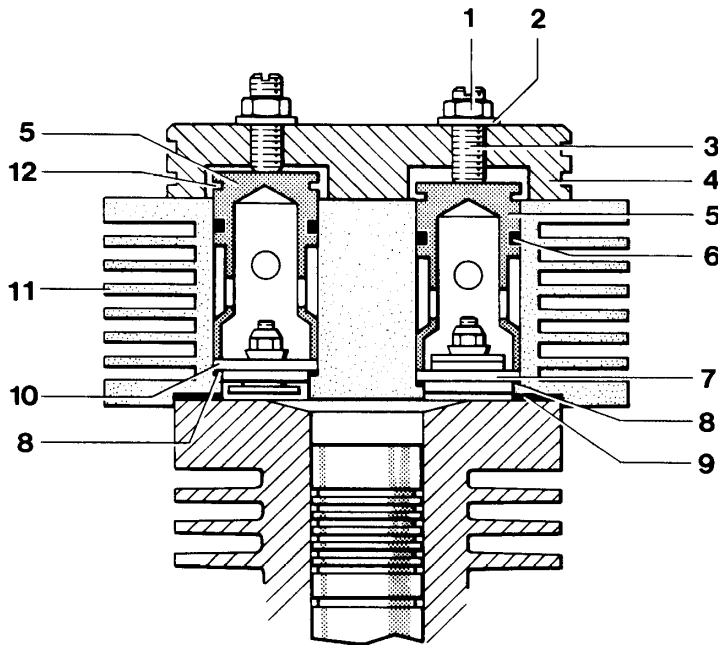

Fig. 56 Valve head and valves, 3rd stage

- 1 Hex. nut
- 2 Lock washer
- 3 Stud
- 4 Valve cover
- 5 Valve cap
- 6 O-ring
- 7 Discharge valve
- 8 Gasket
- 9 Valve head gasket
- 10 Inlet valve
- 11 Valve head
- 12 Groove

Remove and reinstall the valves for replacement as follows (see Fig. 56).

Removal procedure

- Unscrew and remove hex. nuts (1).
- Loosen studs (3) a couple of turns.

Workshop Manual

- Remove six allen screws (not shown) from valve head cover and remove valve cover (4).
- Insert two screwdrivers into groove (12) of the valve cap (5) and lift out valve cap with O–ring (6).
- Check O–ring (6) and replace if required.
- Pull out valves (7) and (10).

Inspection

- Check valve gasket (8) and replace if required.
- Clean valves and check function.
- Replace any faulty parts.

Installation procedure

- Fit new valves with gaskets (8) and locate valve caps (5) with O–rings (6).



The valve cap of the the inlet valve protrudes 3 mm (0.118 in.) more out of the valve head than the valve cap for the discharge valve. Make sure that studs are turned out far enough before installing valve cover.

- Fit valve cap (4)
- Tighten studs (3) by hand.
- Screw on hex. nut (1) and tighten with torque wrench while holding studs in position with a screwdriver.

4.14. COMPRESSOR BLOCKS IK25.4, IK28.2

4.14.1. Changing the valves of the 1st and 2nd stage

The valves are located in the valve heads of the two horizontally positioned cylinders and in the vertical cylinder of the 2nd stage (Fig. 58). Two inlet and two discharge valves are provided.

Remove and reinstall the valves for replacement as follows (see Fig. 57 and Fig. 59).

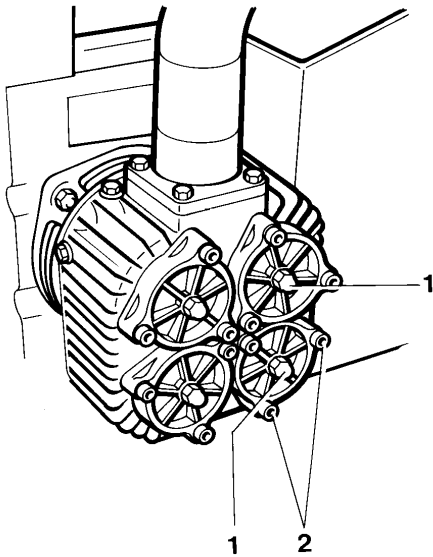

Fig. 57 Valve head 1st stage

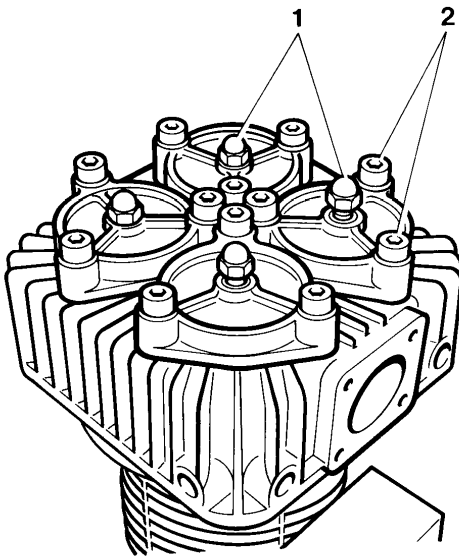

Fig. 58 Valve head 2nd stage

Workshop Manual

Removal procedure

- Unscrew and remove cap nut (1).
- Unscrew stud (4) a number of turns.
- Check, and if required, replace gasket (3).
- Remove valve cover bolts (2) and take off valve cover (5).
- Check O-ring (11) and replace if required.
- Take off valve cap (6) and extract the valve.
- Check valve gasket (8) and replace, if required.

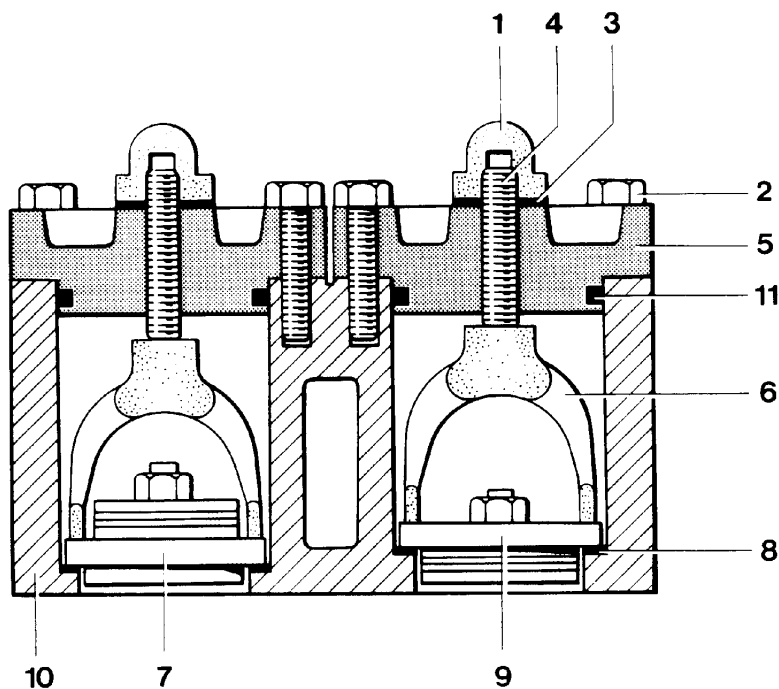

Fig. 59 Valve head and valves, 1st and 2nd stage

- 1 Cap nut
- 2 Valve cover bolt
- 3 Gasket
- 4 Stud
- 5 Valve cover
- 6 Valve cap
- 7 Discharge valve
- 8 Valve gasket
- 9 Inlet valve
- 10 Valve head
- 11 Valve cover gasket (O-ring)

Installation procedure

- Fit new valve with gasket (8) and locate valve cap (6).
- Fit valve cover (5) with O-ring (11) and fasten with bolts (2).
- Tighten bolts diagonally using a torque wrench to the correct value.
- Tighten stud (4) using an allen key and screw on cap nut (1).

4.14.2. Changing the valves of the 3rd stage

The 3rd stage valves are located in the valve head of the 3rd stage. Two inlet and two discharge valves are provided (Fig. 60).

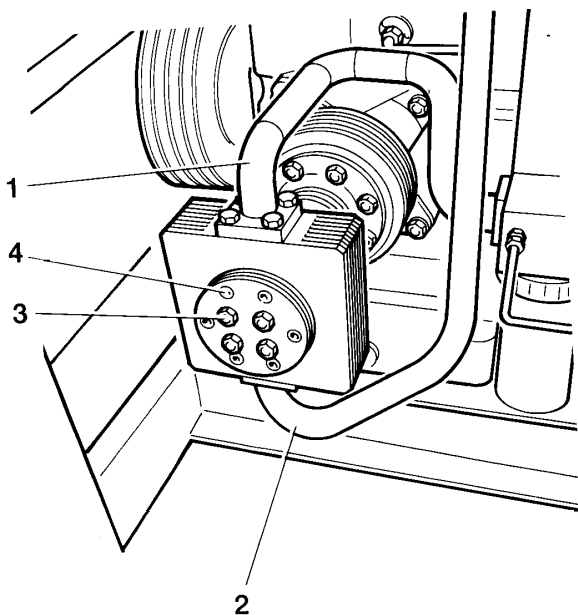

Fig. 60 Cylinder and valve head 3rd stage

- 1 Intake line
- 2 Discharge line
- 3 Mounting nuts for cap holder
- 4 Valve head bolts

Remove and reinstall the valves for replacement as follows (see Fig. 60 and Fig. 61).

Removal procedure

- Remove connecting pipe (1, Fig. 60) between valve head inlet and intermediate separator, 2nd stage.
- Remove connecting pipe (2) between valve head outlet and after-cooler.

Workshop Manual

- Unscrew and remove hex. nuts (3).
- Loosen studs (3, Fig. 61) a couple of turns.
- Remove six allen bolts (4, Fig. 60) from valve head cover and remove valve cover (4, Fig. 61).
- Insert two screwdrivers into groove (12) of the valve cap (5) and lift out valve cap with O-ring (6).
- Check O-ring (6) and replace if required.
- Pull out valves (7) and (10).

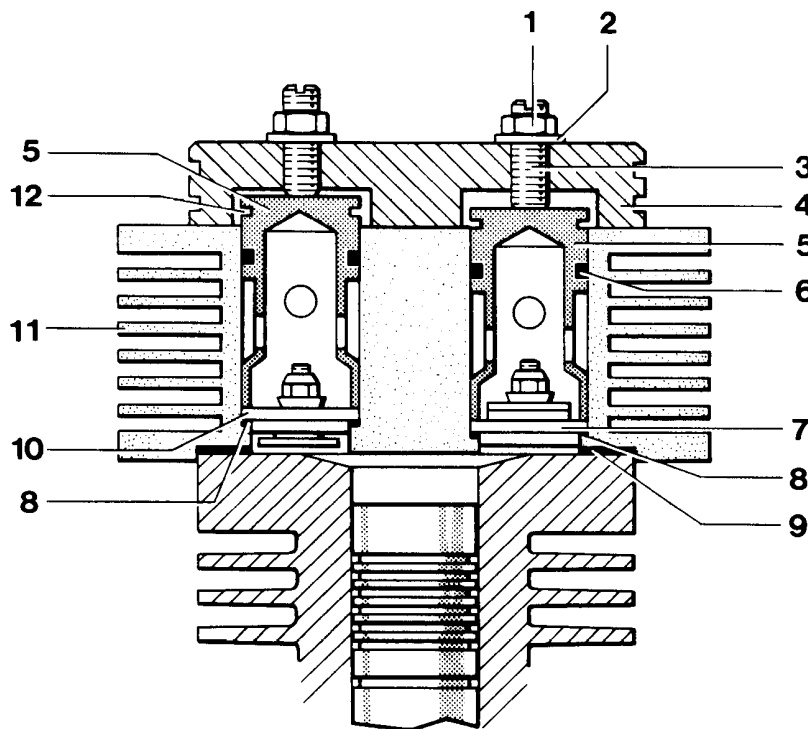

Fig. 61 Valve head and valves, 3rd stage

- 1 Hex. nut
- 2 Lock washer
- 3 Stud
- 4 Valve cover
- 5 Valve cap
- 6 O-ring
- 7 Discharge valve
- 8 Gasket
- 9 Valve head gasket
- 10 Inlet valve
- 11 Valve head
- 12 Groove

Inspection

- Check valve gasket (8) and replace if required.
- Clean valves and check function.
- Replace any faulty parts.

Installation procedure

- Fit new valves with gaskets (8) and locate valve caps (5) with O-rings (6).



The valve cap of the inlet valve protrudes 3 mm (0.118 in.) more out of the valve head than the valve cap for the discharge valve. Make sure that studs are turned out far enough before installing valve cover.

- Fit valve cover (4) with six allen bolts.
- Tighten studs (3) by hand.
- Screw on hex. nut (1) and tighten with torque wrench while holding studs in position with a screwdriver.

Workshop Manual

4.15. COMPRESSOR BLOCK IK25.5, IK28.3

4.15.1. Changing the valves of the 1st and 2nd stage

The valves are located in the valve heads of the two horizontally positioned 1st stage cylinders and in the vertical cylinder of the 2nd stage. Two inlet and two discharge valves are provided.

For removal and reinstallation of the valves refer to 4.14.1.

4.15.2. Changing the valves of the 3rd stage

The 3rd stage valves are located directly on the side of the 2nd/3rd stage stepped cylinder. One inlet valve (1, Fig. 62) and one discharge valve (2) are provided. For removal and reinstallation of the valves refer to 4.13.2.

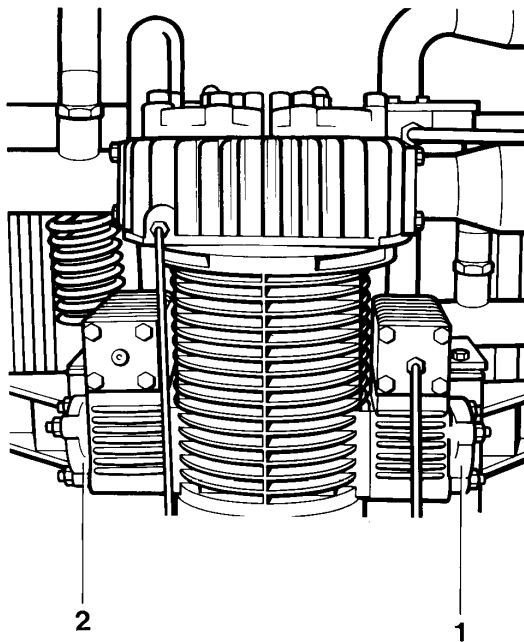

Fig. 62 3rd stage valve head

5. Wear and tear assessment of piston rings, pistons and cylinders

5.1. Procedure

After approximately 4000 hours (8000 operating hours for CNG stations) pistons and cylinders should be checked by performing a **blow-by test**.

What is Blow-By?

Blow-by is defined as the leakage from the compression chambers of each compression stage into the crankcase caused by wear and tear of piston rings and cylinders.

On **BAUER** compressors it is measured with a **flowmeter*** in **liters/minute** and a **backpressure** of **200 bar**. Test point is the crankcase venting outlet. The blow-by test is a simple method to determine the degree of wear of cylinders and pistons without having to dismantle the cylinders.

If during this test increased values outside the specified tolerances should be encountered, it can be assumed that the piston rings and cylinders are excessively worn out. Consequently, those cylinders and piston rings have then to be exchanged. The blow-by values for the different compressor models are listed in the table in 5.3.

Initially, perform the blow-by test for the complete compressor block. If the blow-by is too high, check each single stage to finally find out the faulty cylinder. Start the tests with the last stage. The portion per stage is 1/3rd for three stage blocks, 1/4th for 4 stage blocks, and 1/5th for 5 stage blocks of the the values according to the blow-by table.

5.2. Blow-By Test

Blow-By Test Procedure (Fig. 63)

- Warm up compressor for **15 min.**
- Adjust pressure maintaining valve to **200 bar ±10%**.
- Disconnect vent line from crankcase vent opening and connect flowmeter.
- Perform test (t = 2 min.)
- Compare measured value with blow-by table
- Remove flowmeter and reconnect vent line to 1st stage valve head
- If measured value is above the indicated max. value in the table, replace piston rings of all stages and, if required cylinders and the free-floating piston of the last stage.

* available through BAUER service dept.; 0–50 l/min :part no. 81187–KD; 0–100 l/min :part no. 81188 –KD

Workshop Manual

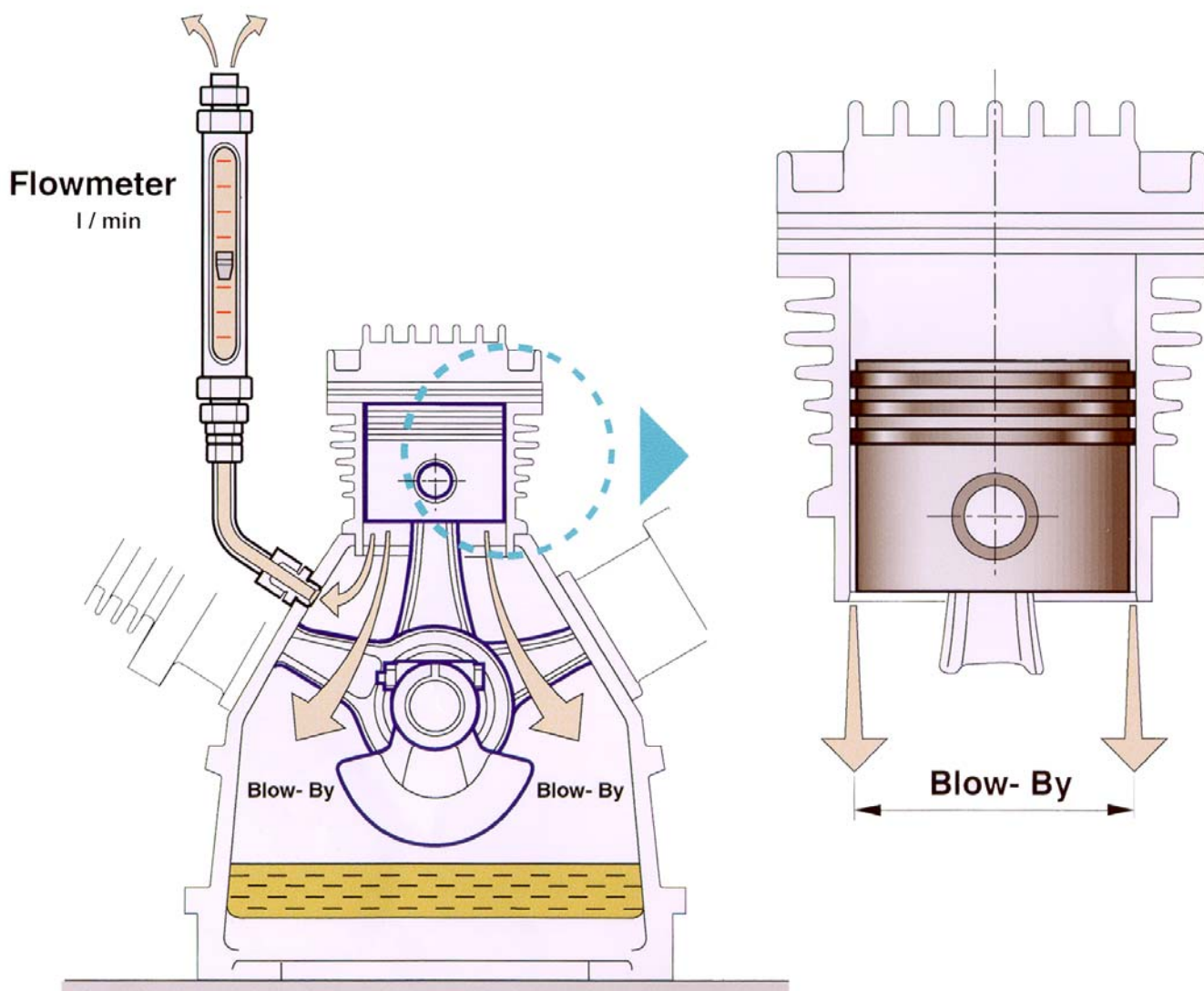

Fig. 63 Blowby test

5.3. Blow-By Table

Flowmeter *: 50 l/min; atm.; 20°C ambient temperature

Note: the lower the blow-by, the better run-in are cylinder and piston rings

Compressor block model	Modification no. (state of construction)	Blow-By [ltr./min]		Pressure maintaining valve set pressure [bar] ±10%
		<i>standard</i>	<i>max.</i>	
UTILUS II	04	18	25	200
CAPITANO II	04	18	25	200
MARINER II	04	25	35	200
K100	03	10	15	200
IK100 II	04	18	25	200
K120	03	10	15	200
IK120 II	04	25	35	200
K14	08	25	40	200
IK12.14 II	01	44	60	200
K15	06	30	45	200
K150	09	30	45	200
IK150 II	10	25	40	200
IK15.11	01	25	40	200
K180	04	30	45	200
IK180 II	05	30	45	200
K18.1	03	90	130	200
IK18.1 II	04	65	100	200
2Ö	04	20	35	200
3Ö	09	20	35	200
3,5Ö	01	25	40	200
3,7Ö	02	45	70	200
4Ö	01	60	90	200

For all booster compressor blocks the Blow-By is depending from the intake pressure (please contact the BAUER service dept.)

* available through BAUER technical service

Workshop Manual

6. Cylinders and Pistons

6.1. General



Before starting to dismantle cylinders, necessarily perform a blow-by test. If blow-by values are o.k. it is not necessary to remove the cylinders.

When repairing pistons and piston rings, observe correct order of piston rings at reassembly. Refer to parts list.

When mounting the piston rings, also check that the "TOP" sign on the rings points upwards, with exception of the lower tapered rings on compressor blocks with stepped pistons. Those are mounted with the "TOP" sign pointing downwards. The "TOP" sign should always be towards the compression chamber (Fig. 64).

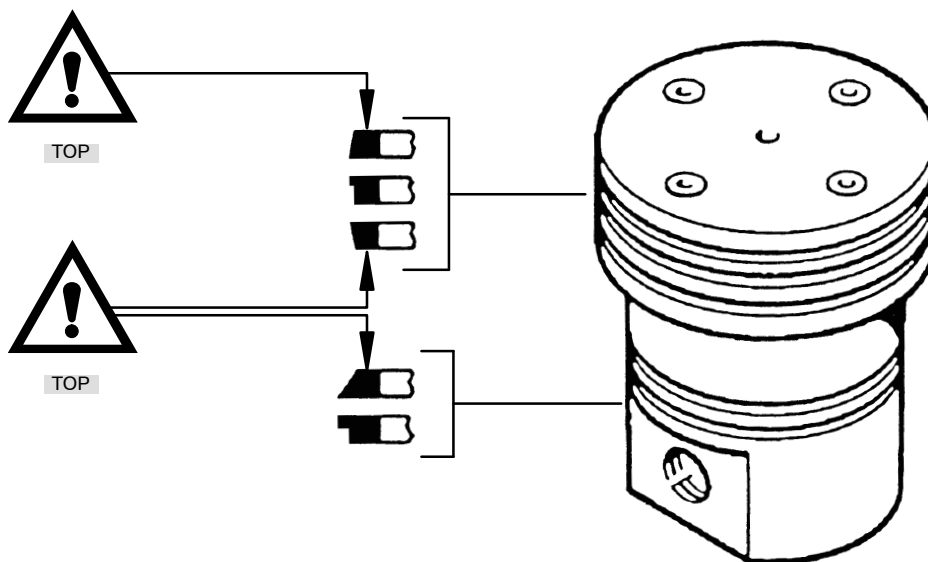

Fig. 64 Piston rings in a stepped cylinder



When reassembling two-part stepped pistons, make sure that the original orientation of both parts to each other is restored. This is marked with cast-in arrows and/or stamped letters (Fig. 65). This applies to the following compressor models: K12.14, K22.0, K22.10, K23.0, K23.1, K25.0, K25.5, K25.9, K25.18 and K28.3.

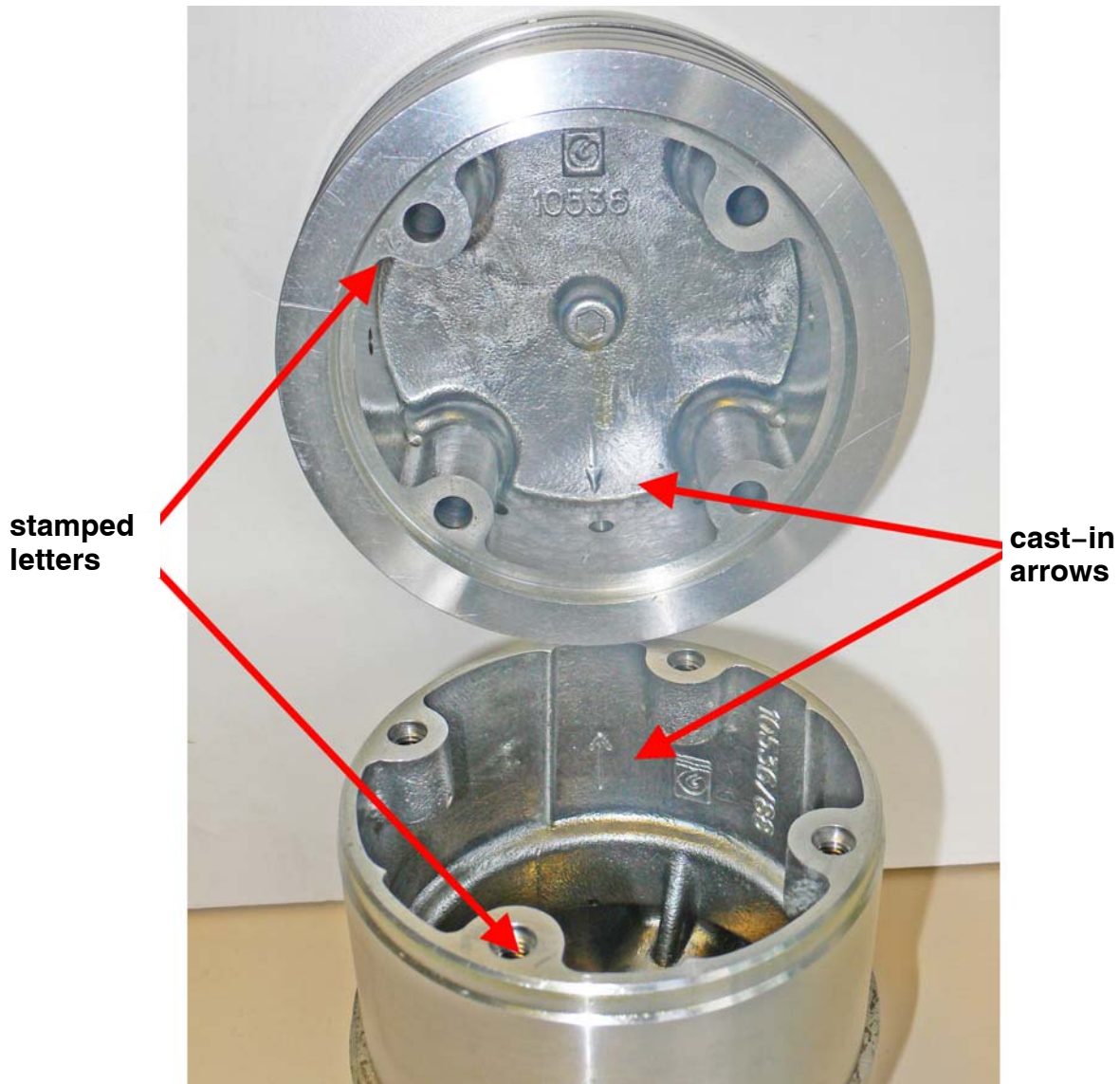

Fig. 65 Stepped piston marks

Workshop Manual

6.2. Wear characteristics on piston rings:

The piston ring wear should always be looked at in connection with the cylinder wear, only.

- Visible scratches and grooves on the surface
- Silvery shining toeing on complete surface (tapered rings)
- Significant reduced thickness (compared to new rings)
- Piston rings gummed up in the piston grooves
- Piston ring ends deteriorated (ground off)
- Uneven wear (toeing)
- Worn out piston grooves
- Broken rings

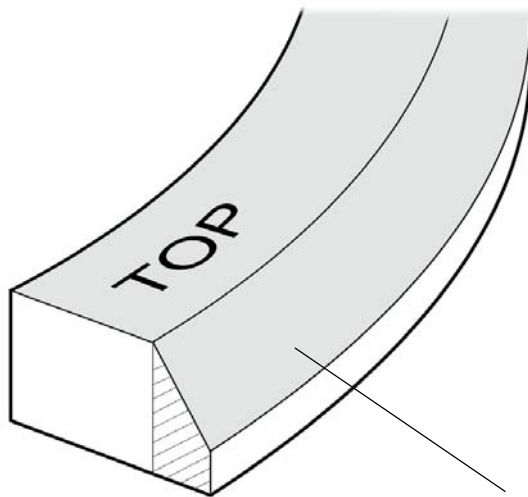

Angular view, magnified approx. 100 times; the real angle is less than 1'.

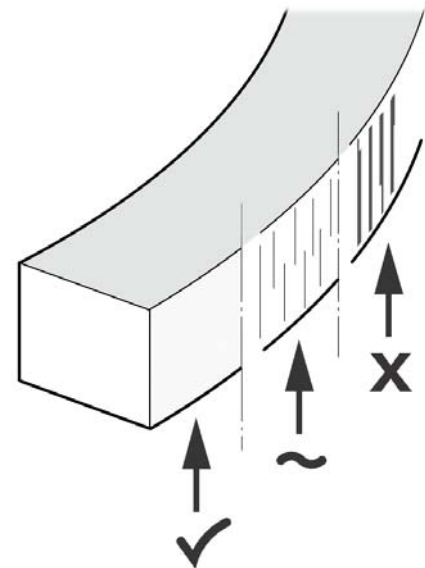

Fig. 66 Wear signs of piston rings

6.3. Wear characteristics on cylinders:

The cylinder wear should always be looked at in connection with the piston ring wear, only.

- Visible scratches, grooves >0,1 mm, signs of seizing
- Dark grey / brown discolouration
- Cracks
- Damaged threads
- Hone image not visible

6.4. Wear characteristics on pistons:

Aluminium and cast iron pistons

The piston wear should always be looked at in connection with the piston ring and cylinder wear, only.

- Visible scratches and grooves, signs of seizing
- Dark grey / brown discolouration
- Polished surface on the lathe turn image
- Worn out piston pin bore
- Worn out piston pin

Workshop Manual

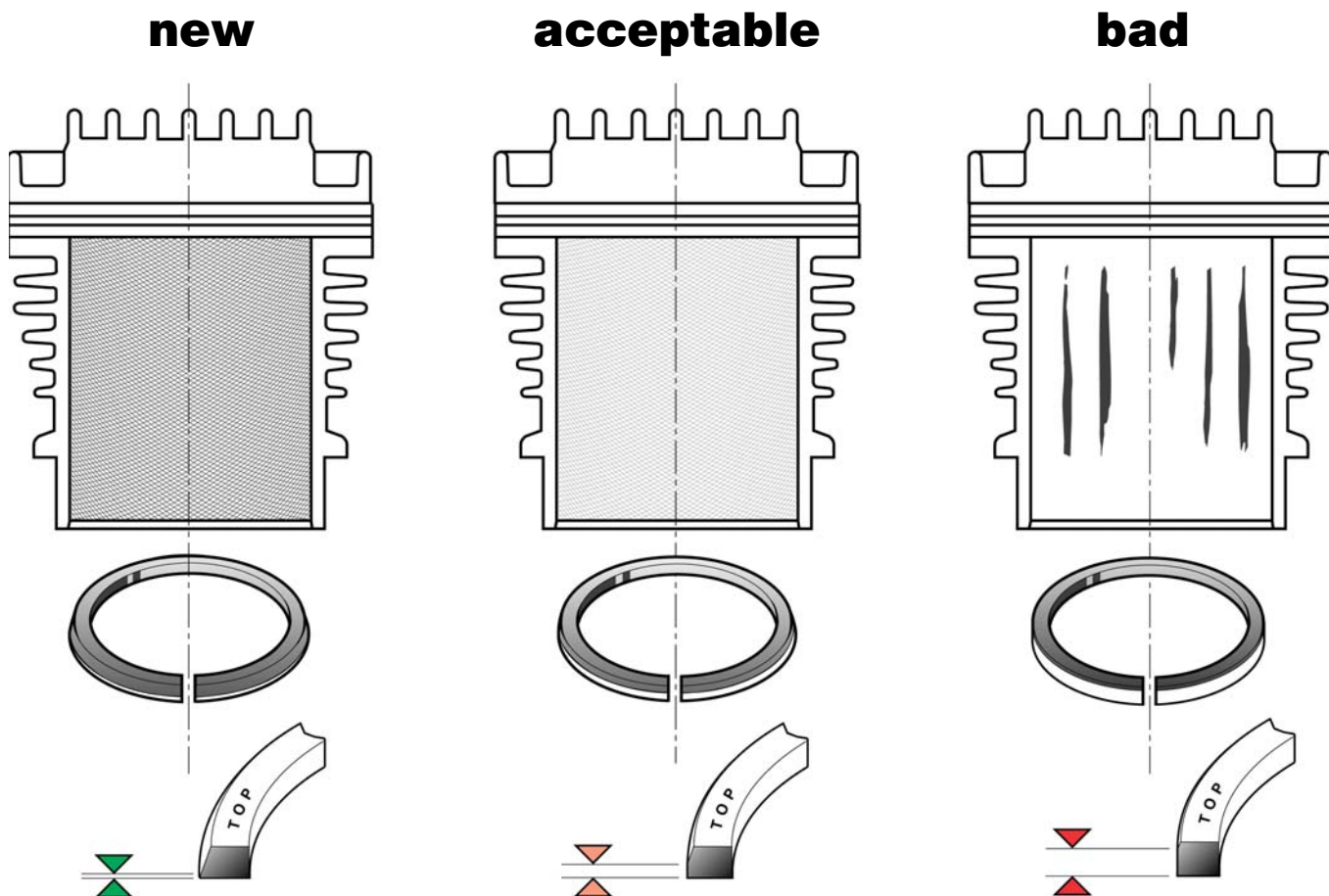

Fig. 67 Cylinder wear

6.5. Piston ring gap test



The piston ring gap test should only be considered as a secondary means of determining the piston and cylinder wear.

- Remove the piston with piston rings.
- Remove the piston rings from the piston.
- Insert the piston rings in the corresponding cylinder approx. 10 mm (3/8") from the top edge. Check the piston ring gap with feeler gauge part no. N20889, see Fig. 68.
- Change the piston rings if permissible values are exceeded.
- Dismantle pistons with piston rings.
- Remove piston rings from pistons.

Max. allowable piston ring gap		
Cylinder-Ø (mm)	Gap min. (mm)	Gap max. (mm)
215	1,35	1,60
185	1,20	1,45
170	1,10	1,30
160	1,05	1,25
150	1,00	1,20
140	0,95	1,15
130	0,90	1,15
50	0,50	0,70
45	0,45	0,65
36	0,40	0,55
28	0,37	0,45
24	0,35	0,45
22	0,33	0,40
18	0,30	0,40
16	0,30	0,35

Workshop Manual

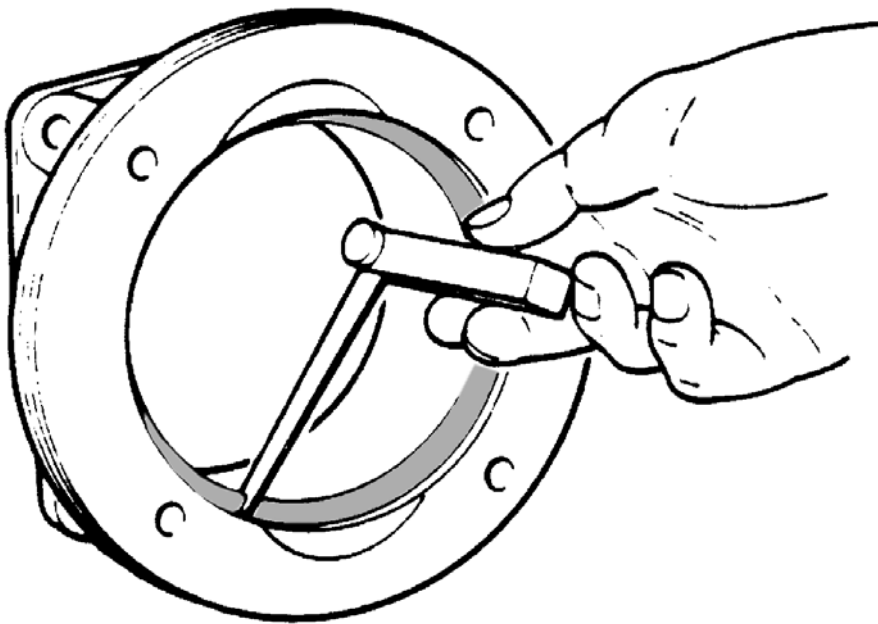

Fig. 68 Checking the piston ring gap

6.6. Mounting instructions for piston rings

- Change **piston rings** only as a **complete set**. Observe correct order and orientation.
- For dismantling or mounting of piston rings with larger diameters use respective piston ring pliers. Refer to special tools table.
- Remove preservation compound from new rings.
- Lubricate rings and inside of cylinders well with compressor oil.
- Mount ring gaps with 180° offset to each other.
- TOP marks of the rings should point towards the compression chamber.

7. Oil quantities

Compressor model	Oil – Max. [ltr.]	Oil – Min. [ltr.]	Top-up quantity [ltr.]	Oil filter [ltr.]
U-10, JUNIOR, JUNIOR II	0,35 "	0,28 "	~ 0,07 "	– –
OCEANUS	01,30	01,10	~ 0,20	–
UTILUS CAPITANO MARINER	01,75 " "	01,50 " "	~ 0,25 " "	– – –
UTILUS II CAPITANO II MARINER II	02,90 " "	02,40 " "	~ 0,50 " "	intern intern intern
IK 100, IK120	02,80	02,40	~ 0,40	–
IK100 II, IK120 II IK12.14 II	02,90 "	02,40 "	~ 0,50 "	Intern Intern
K14, K14.11	02,80	02,20	~ 0,60	–
K15, K16, K150, K180, K18.1	04,40 " "	04,10 " "	~ 0,30 " "	– – –
IK150 II, IK180 II IK18.1 II	06,00 "	04,40 "	~ 1,60 "	Intern Intern
IK22.0, IK22.5	08,50	06,75	~ 1,75	~ 0,50
IK23.0, IK23.4	10,50	08,30	~ 2,20	~ 0,50
IK25.0, IK25.4, IK25.5, IK25.9 IK25.18, IK28.0, IK28.2, IK28.3,	34,00 " " "	25,00 " " "	~ 9,00 " " "	~ 1,00 " " "
2Ö, 3Ö, 3,5Ö 3,7Ö	01,70 "	01,35 "	~ 0,35 "	– –
4Ö	06,00	04,50	~ 1,50	~ 0,5

The exact oil quantities have to be checked with oil dipstick or oil sight gauge, depending on the compressor model.

For recommended compressor oils refer to oil list.

Workshop Manual

8. Condensate valves

General information

The automatic condensate drain unit ensures regular and reliable drainage of the condensate produced due to the recooling after compression process. It will also increase the lifetime of the filter cartridges in the purifying systems many times over.

Furthermore, a correctly adjusted condensate drain unit will reduce premature wear of the free floating piston of the final stages and dynamic pressure load on the final separator pressure vessels.

We recommend:

- Check automatic condensate drain units every **500 operating hours** at least annually for correct function (by means of intermediate pressure gauges*)
- Every **1000 operating hours** at least every 2 years replace inner parts (e.g. gaskets, sealing rings, o-rings, valve seats, pistons) – use maintenance kits*.
- Dismantle defective condensate drain valves according to drawing and clean parts, preferably in ultrasonic cleaning bath.
- Replace parts subject to wear and tear.
- If heavily damaged parts are encountered (e.g. damaged threads) replace complete drain valve.
- After maintenance work readjust pressure loss (Δp) and drain interval and drain time (Δt).
- For all final separators a Δp of max. 50% of the operating pressure is recommended.
- The Δt of the automatic condensate drain unit has to be set according to the compressed medium (refer to operating manual).

* BAUER parts service / technical service

Condensate drain valves, normally open type

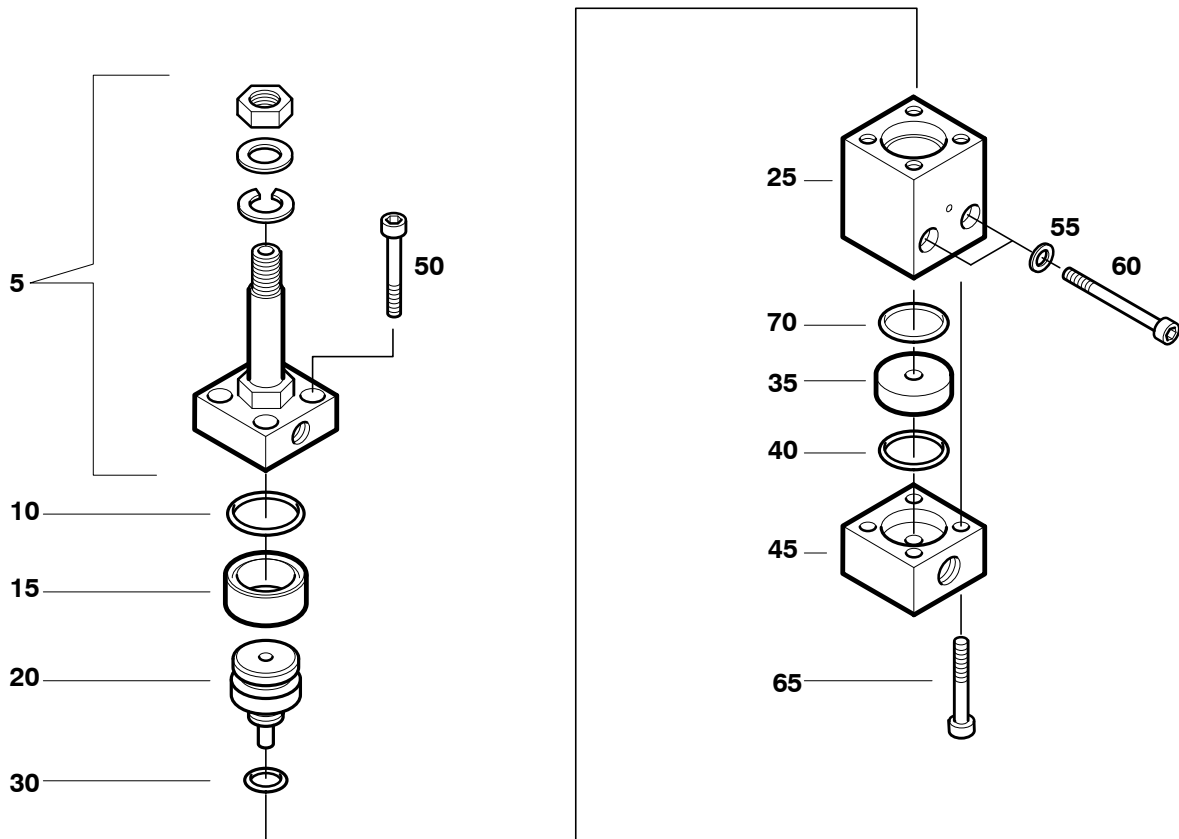

Disassembly:

- Remove hex nut and electric coil
- Remove allen screws (50) and solenoid valve (5)
- Remove o-ring (10).
- Screw allen screw (50) some turns into piston (20).

Workshop Manual

- Pull piston (20) out of housing (25).
- Remove allen screw (65) and lower housing (45).
- Remove valve seat (35) and o-rings (40) and (70). Clean parts, preferably in ultrasonic cleaning bath. Replace worn parts. If possible, use maintenance kits*. If heavily damaged parts are encountered (e.g. damaged threads) replace complete drain valve.

Assembly:

- Assemble parts in the reverse order of disassembly
- Tighten all screws with torque wrench (refer to torque table)

* BAUER parts service / technical service

Condensate drain valves, normally closed type

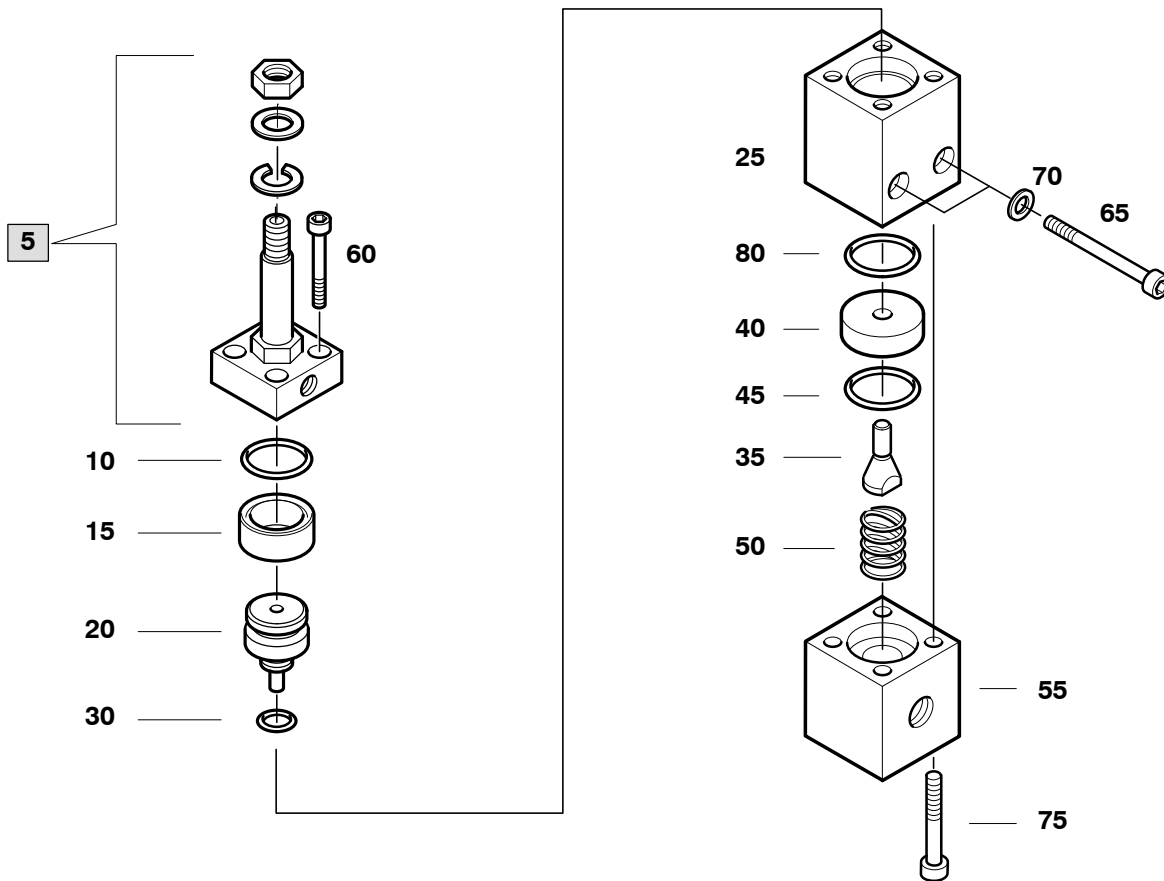

Disassembly:

- Remove hex nut and electric coil
- Remove allen screws (60) and solenoid valve (5)
- Remove o-ring (10).
- Screw allen screw (60) some turns into piston (20).
- Pull piston (20) out of housing (25).

Workshop Manual

- Remove allen screws (75) and lower housing (55).
- Remove valve seat (40) and o-rings (80) and (45), Piston (35) and spring (50). Clean parts, preferably in ultrasonic cleaning bath. Replace worn parts. If possible, use maintenance kits*. If heavily damaged parts are encountered (e.g. damaged threads) replace complete drain valve.

Assembly:

- Assemble parts in the reverse order of disassembly
- Tighten all screws with torque wrench (refer to torque table)

* BAUER parts service / technical service

9. Pressure maintaining valves

General information

The pressure maintaining valves ensure a correct and reliable operation of the air and gas compressors and of the air and gas processing systems.

Furthermore, they will reduce dynamic pressure load on the purifier pressure vessels.

- We recommend to check the pressure maintaining valves every **500 operating hours** at least annually for correct function.
- Every **1000 operating hours** at least every 2 years replace inner parts (e.g. gaskets, sealing rings, o-rings, valve seats, pistons) – use maintenance kits*.
- Dismantle defective pressure maintaining valves according to sectional drawings and clean parts, preferably in ultrasonic cleaning bath.
- Replace parts subject to wear and tear.
- If heavily damaged parts are encountered (e.g. damaged threads) replace complete valve.
- After maintenance work readjust opening pressure – refer to tables on next page.

* BAUER parts service / technical service

Workshop Manual

Pressure setting for pressure maintaining valves

Medium pressure units

Operating pressure of unit	Adjusted opening pressure
30 bar	20 bar
40 bar	25 bar
50 bar	30 bar
60 bar	40 bar
70 bar	45 bar
90 bar	55 bar

For other compressor unit final pressure setting, we recommend to adjust the opening pressure to 60% of the compressor unit operating pressure.

High pressure units

Operating pressure of unit	Adjusted opening pressure
150 bar	100 bar
200 bar	150 bar
300 bar	170 bar
350 bar	180 bar
400 bar	200 bar
500 bar	300 bar

For other compressor unit final pressure setting, we recommend to adjust the opening pressure to 60% of the compressor unit operating pressure.

Adjustment of the pressure maintaining valves

How to determine the opening pressure of the pressure maintaining valve:

As long as the pressure built up by the compressor is below the adjusted opening pressure of the pressure maintaining valve, the final pressure indication remains at zero. But, the pressure building up in front of the pressure maintaining valve can be read from the pressure gauge mounted at the filter system venting valve. When the pressure maintaining valve opens, the final pressure gauge will begin to show the rising pressure. At this moment, read the opening pressure from the pressure gauge at the filter system.

This method is not possible on units without filter system (mostly medium pressure units). In this case, a test pressure gauge (see high pressure accessories catalog) has to be mounted at the test connector of the final separator.

Pressure maintaining valves

Type	Part no.	Operating pressure	outlet Ø
2	056705	400 bar	10 mm
2	057351	350 bar	1/4 NPT
2	060510	400 bar	12 mm
2	062516	150 bar	8 mm
1	063838-KD	350 bar	8 mm
1	065469-KD	350 bar	8 mm
3	068275	500 bar	8 mm
2	068385	350 bar	10 mm
5	071043-KD	150 bar	8 mm
3	071386	500 bar	6 mm
1	075330	350 bar	8 mm
1	075413-KD	350 bar	8 mm
1	090062-KD	350 bar	8 mm
1	80751	350 bar	
1	80760	350 bar	
1	80804	350 bar	
1	80815	350 bar	

Workshop Manual

Type 1 Compressor units up to 350 bar, max. 650 l/min.

The opening pressure is adjustable with screw (1, Fig. 69). First loosen counter-nut (2) and turn out stud (3) several turns.

Turning cw increases pressure

Turning ccw reduces pressure

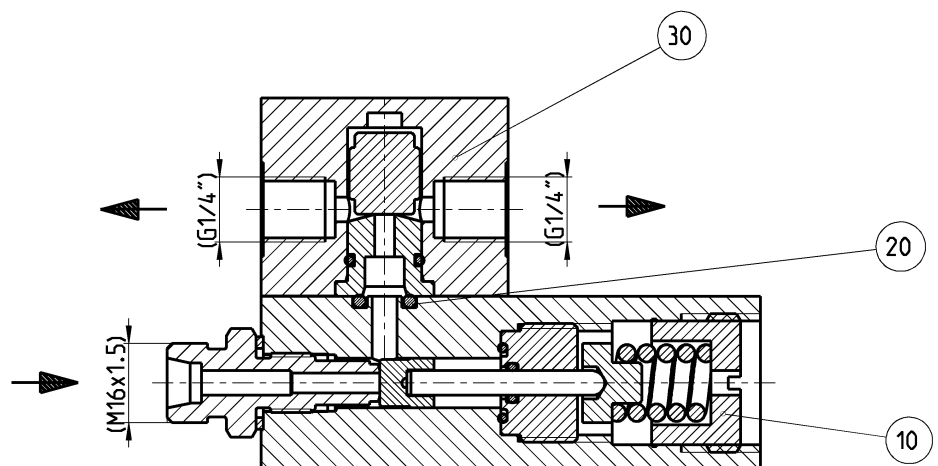
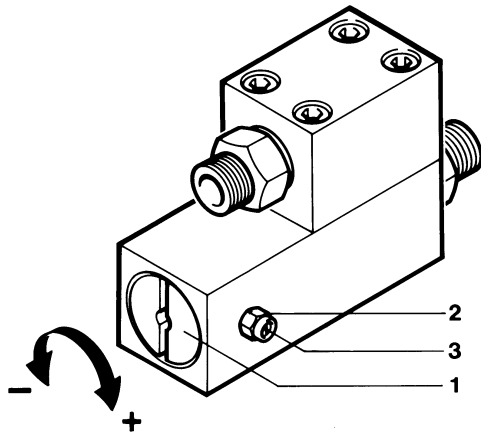

Fig. 69 Pressure maintaining valve

Type 2 Compressor units up to 350 bar, max. 3600 l/min.

The opening pressure is adjustable with screw (1, Fig. 70). First turn out stud (2) several turns.

Turning cw increases pressure
Turning ccw reduces pressure

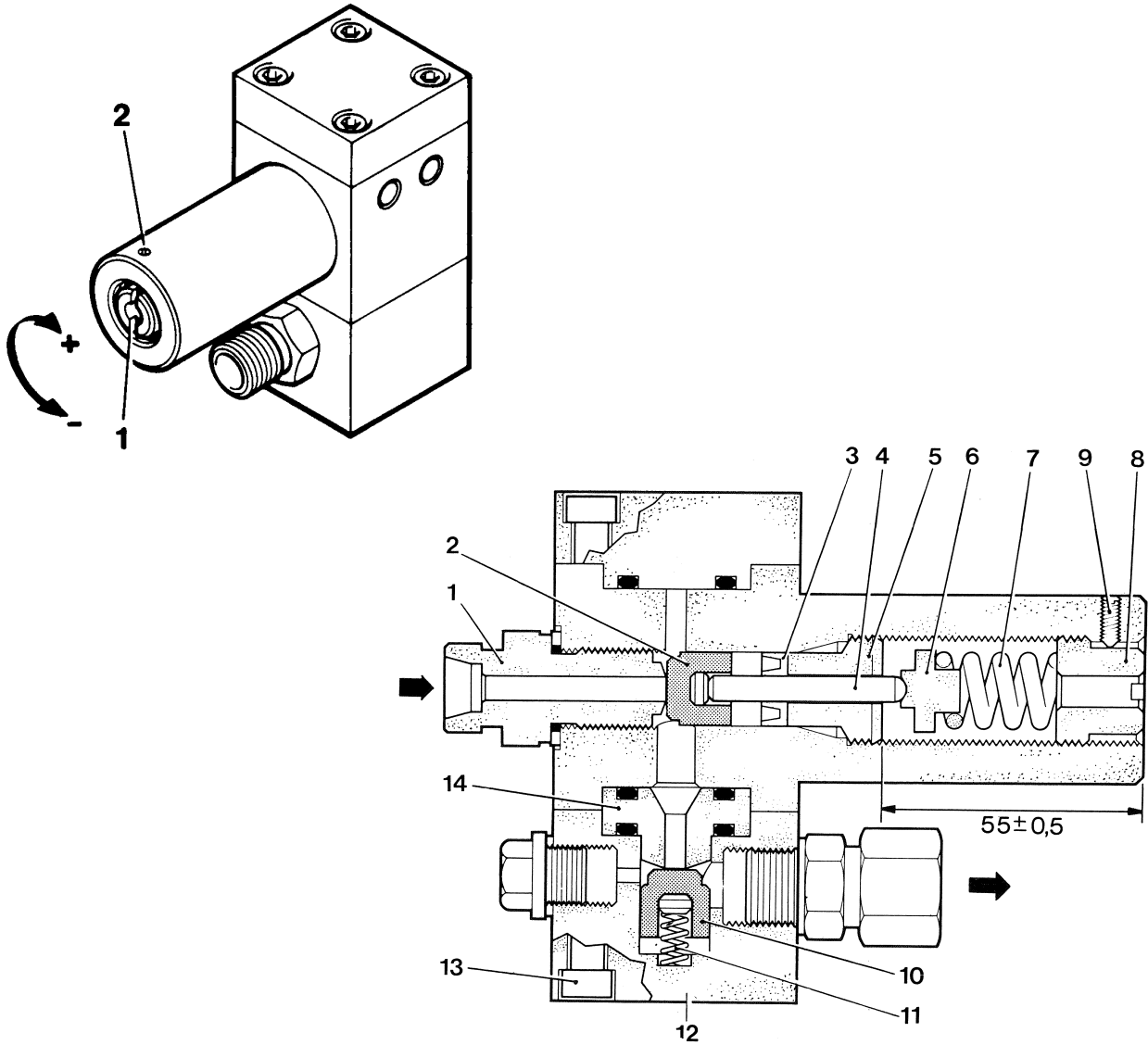

Fig. 70 Pressure maintaining valve, 350 bar units /3600

Workshop Manual

Type 3 Compressor units up to 500 bar, max. 650 l/min.

The opening pressure is adjustable with screw (1, Fig. 71). First turn out stud (2) several turns.

Turning cw increases pressure
Turning ccw reduces pressure

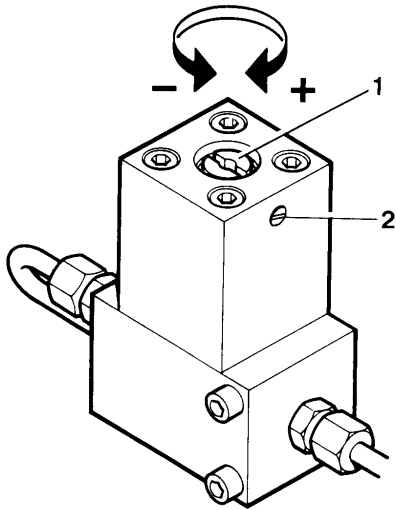

Fig. 71 Pressure maintaining valve, 500 bar units

Type 4 Compressor units up to 90 bar, max. 7500 l/min.

Remove cover (1).

The opening pressure is adjustable with key (2, Fig. 72).

Turning cw increases pressure

Turning ccw reduces pressure

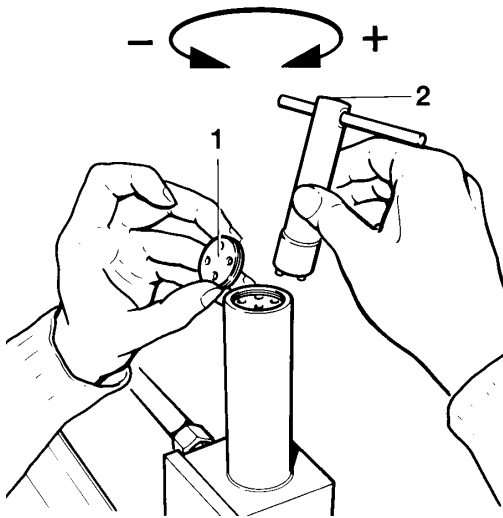





Fig. 72 Pressure maintaining valve, 90 bar units

Lubricating oil list

1. GENERAL

After extensive tests with many different kinds of lubricants, we have decided to authorize the following brands of oil for use in **BAUER** compressors under the given operating conditions.

This list is up to date at the time of printing and will be reviewed continuously. Should your list or your instruction manual be older, please request the latest edition from **BAUER** Customer Services. When using any of the oils listed below, please follow the oil change intervals and the oil filling level described for the equivalent **BAUER** compressor oil in the instruction manual of your unit.

Oil type			Use						Ambient temperature
Brand name	Designation	Type	A Breathing air	N Nitrox	I Industrial air	G Helium, Argon	C CNG	GI Nitrogen	
	Special Compressor oil Part no. N28355 b) c)	S	+	+	+	+	-	+	+5 ... +45 °C
	Special Compressor oil Part no. N22138 a)	M	+	-	+	-	-	-	+5 ... +45 °C
	Special Compressor oil Part no. N26303 b)	S	-	-	-	-	+	-	+5 ... +45 °C
	Special Compressor oil Part no. N30387 b)	S	-	-	-	-	-	+	+10 ... +45 °C *

Oil type

S	synthetic oil
M	mineral oil

Application

A	approved for breathing air application with BAUER air purification systems
N	approved for nitrox application with BAUER membrane unit
I	suitable for industrial air compressor units
G	suitable for gas compressor units for dry and highly pure gases
C	suitable for compressed natural gas compressors (CNG filling stations)
GI	suitable for gas compressor units for nitrogen
a)	oil change every 1000 operating hours
b)	oil change every 2000 operating hours
c)	oil change every 1000 operating hours in case of nitrox application

Suitability

+	= suitable
◆	= partly suitable
-	= not suitable

2. TYPE OF OIL

Due to the thermal load on the compressor only high quality oil should be used. You are recommended to restrict oils to those which have been approved by us and are listed in the instruction manual or in the lubricating list on page 1.

Our compressor units are delivered ex works with lubricating oil filled into the crankcase or as consignment, depending on the model, as follows:

Breathing air compressor units:	BAUER Special Compressor oil, part no. N28355
Nitrox compressor units:	BAUER Special Compressor oil, part no. N28355
Industrial air and gas compressor units:	BAUER Special Compressor oil, part no. N28355
CNG compressor units:	BAUER Special Compressor oil, part no. N26303
Nitrogen compressor units:	BAUER Special Compressor oil, part no. N30387*

For operation under difficult conditions, such as continuous running and/or high ambient temperatures, we only recommend the BAUER special synthetic compressor oils acc. to the list on the previous page. These have proved excellent quality under ambient temperatures between +5 °C and +45 °C. For lower temperatures a compressor heating device is required which is capable of pre-heating the unit up to +5 °C.

For operation under less severe conditions, and for intermittent operation, i.e. when the compressor is not used for longer periods between the operating periods, we also recommend the use of the mineral oil acc. to the list on the previous page. This oil is suitable for ambient temperatures between +5 °C and +45 °C. Here also, a pre-heating device will be required if ambient temperatures should fall below +5 °C.

2.1. Changing the Oil Type

CAUTION

To avoid severe damage to the compressor unit when changing to another oil type, the following measures should be strictly adhered to.

- Drain mineral oil while still warm.
- Check valves, coolers, separators, purifiers and all pneumatic tubes and hoses for deposits.

If deposits are present, perform the following steps:

- Remove deposits or change valves, coolers, separators, purifiers and all pneumatic tubes and hoses.
- Change oil filter, if applicable.
- Fill compressor with the new oil.
- After approx. 100 operating hours, replace oil filter again (if applicable). and change oil.
- Top up with same oil type.

3. OIL CHANGE

Mineral oil	every 1000 operating hours, at least annually
Synthetic oil	every 2000 operating hours, at least every two years
Oil change volume	see compressor unit operating manual

BAUER compressor oil is available in the following quantities:

Oil quantity ➡ Oil type ▶	Synthetic oil N28355	Synthetic oil N26303	Mineral oil N22138	Synthetic oil N30387*
1 ltr. bottle	part no. N28355-1	part no. N26303-1	part no. N22138-1	part no.N 30387-1
5 ltr. container	part no. N28355-5	part no. N26303-5	part no. N22138-5	part no.N 30387-5
20 ltr. container	part no. N28355-20	part no. N26303 -20	part no. N22138-20	part no.N 30387-20

* Compressor oil N30387 is suitable for ambient temperatures between +10 °C and +45 °C. For lower temperatures a compressor heating device is required which is capable of pre-heating the unit up to +10 °C.